

- Energy Meters p16-1
- Data Concentrators p16-3
- Digital Measuring Instruments p16-4
- Expansion Modules and Accessories p16-15
- Current Transformers p16-19
- Software and Applications p16-22
- Systems Management p16-28

16

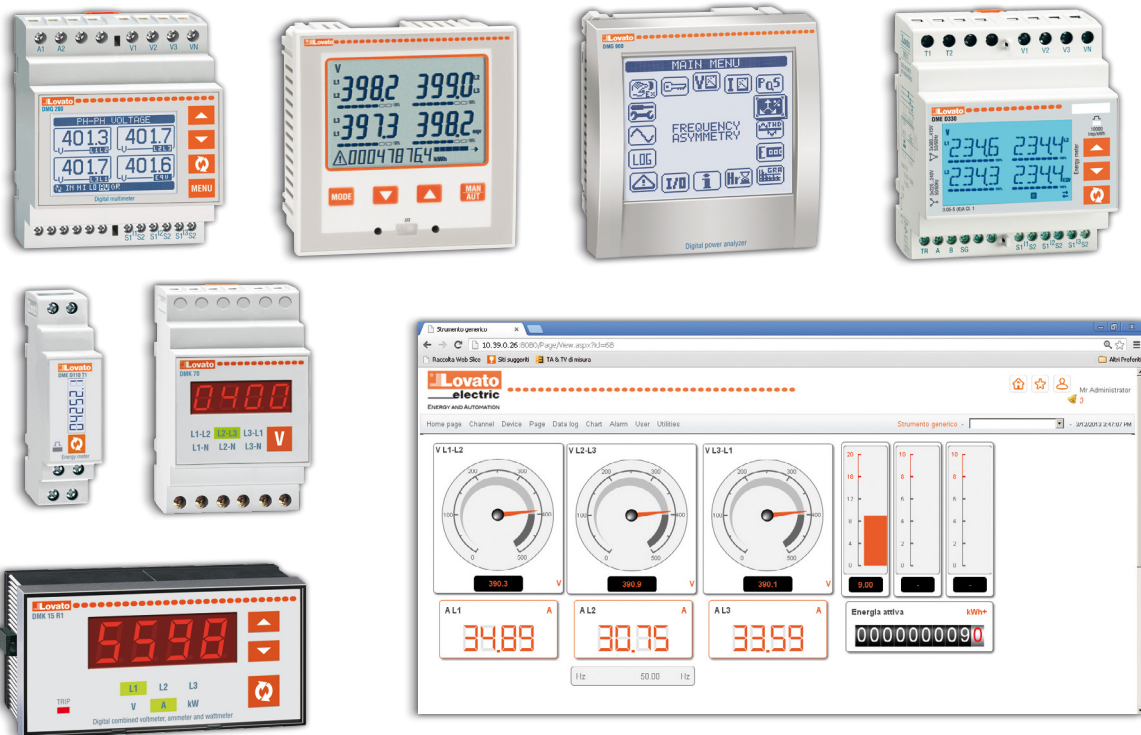

Single phase, non expandable



DME M100



DME D110 T1...



DME D115 T1...
DME D120 T1... - DME D121

Order code	Description	Qty per pkg	Wt
		n°	[kg]
Mechanical meter with mechanical display.			
DME M100	32A direct connection, 1U	1	0.084
DME M100 T1	32A direct connection, 1U 1 pulse output	1	0.088
Digital meter, with LCD screen.			
DME D100 T1	40A direct connection, 1U 1 pulse output, 220...240VAC	1	0.086
DME D100 T1 A120	40A direct connection, 1U 1 pulse output, 110...120VAC	1	0.086
DME D110 T1	40A direct connection, 1U 1 program. static output, multi-measurements ①, 220...240VAC	1	0.090
DME D110 T1 A120	40A direct connection, 1U 1 program. static output, multi-measurements ①, 110...120VAC	1	0.090
Digital meter with backlight LCD screen.			
DME D115 T1	40A direct connection, 2U, 1 program. static output, multi-measurements ②, 220-240VAC	1	0.090
DME D120 T1	63A direct connection, 2U 1 program. static output, multi-measurements ①, 220-240VAC	1	0.148
DME D120 T1 A120	63A direct connection, 2U 1 program. static output, multi-measurements ①, 110...120VAC	1	0.148
DME D121	63A direct connection, 2U, RS485 interface multi-measurements ①, 220-240VAC	1	0.148

General characteristics

The energy meters are instruments for energy consumption measurement in single-phase installations with direct connection.

Operational characteristics

DME M... (mechanical display)

- Rated supply voltage: 230VAC -20...+15%
- Direct connection
- 32A maximum current
- Active energy measurements
- Active energy accuracy: Class 1 (IEC/EN 62053-21)
- Mechanical meter with 6+1 digit count
- Flashing LED for consumption indication
- Static pulse output for DME M100 T1 only
- Modular DIN 43880 housing, 1 module
- Sealable terminal blocks, standard supplied
- IEC degree of protection: IP40 on front; IP20 at terminals.

DME D110T1-DME D110 T1-DME D115 T1-DME D120 T1-DME D121-DME D130

- Nominal supply voltage:
 - 220...240VAC for DME D...T1
 - 110...120AC for DME D...T1 A120
- Voltage range:
 - 187...264VAC for DME D... T1
 - 93...132VAC for DME D...T1 A120
- Direct connection
- Maximum current: 40A for DME D100 T1, DME D110 T1..., DME D115 T1; 63A for DME D120 T1 - DME D121 - DME D130
- Active energy measurement and accuracy: Class 1 (IEC/EN 62053-21)
- Reactive energy measurement and accuracy: Class 2 (IEC/EN 62053-23) except for DME D115 T1
- LCD meter : With 5+1 digit count for DME D100/110 T1...; backlight with 6+1 digit count for DME D115 T1, DME D120 T1, DME D121, DME D130
- Metrological LED with pulse emission for consumption indication
- Clearable partial energy measurement except for DME D100/110 T1...
- One output: Pulse for DME D100 T1; programmable static for all other types
- Built-in RS485 port for DME D121; compatible with Synergy
- Modular housing, 1 module for DME D100 T1, DME D110 T1; 2 module for all other types
- Sealable terminal blocks, standard supplied
- protection degree: IP40 on front; IP20 at terminals.

Synergy supervision and energy management software. See page 16-22.

EXM series expansion modules see page 16-16.

Certifications and compliance

Certifications obtained: EAC, cULus for DME D... type
Compliant with standards: IEC/EN 61326-1 for DME M... type; EN 50740-3, IEC/EN 61010-1, UL 61010-1, CSA C22-2 n° 61010-1 for DME D... type.

① Multi-measurements:

- Total and partial active energy
- Total and partial reactive energy
- Voltage
- Current
- Active and reactive power
- Power factor
- Frequency
- Total and partial hour counter
- Average active power (calculation on every last 15 minutes)
- Maximum demand.

② Multi-measurements:

- Total and partial active energy
- Active power
- Average active power (calculation on every last 15 minutes)
- Maximum demand.

Single phase, expandable



DME D130

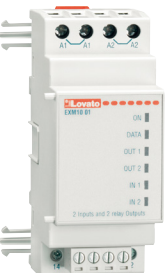

EXM10 01

Order code	Description	Qty per pkg	Wt
		n°	[kg]
Digital meter with backlight LCD screen.			
DME D130	63A direct connection, 2U, multi-measurements ①, expandable, 220-240VAC	1	0.148
Order code			
Description			
DME D130 EXPANSION MODULES.			
Inputs and outputs.			
EXM10 01	2 opto-isolated digital inputs and 2 relay outputs 5A 250VAC		

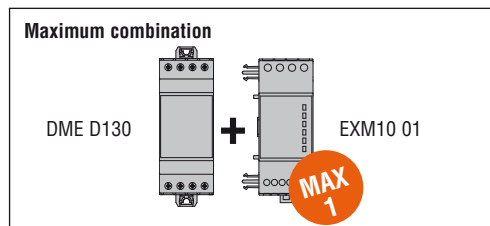

Three phase with or without neutral, non expandable



DME D300 T2



DME D330



Order code	Description	Qty per pkg	Wt
		n°	[kg]

Digital meter for three phase with neutral.

DME D300 T2	63A direct connection, 4U, 2 programmable static outputs, multi-measurements ❶	1	0.360
DME D301	80A direct connection, 4U RS485 interface, multi-measurements ❶	1	0.360
DME D305 T2	Connection by CT /5A, 4U, 2 programmable static outputs, multi-measurements ❶	1	0.332

Digital meter for three phase with or without neutral.

DME D330	Connection by CT /5A sec. 4U, RS485 interface, multi-measurements ❶	1	0.332
----------	---	---	-------

Three phase with or without neutral, expandable



DME D310 T2



EXM10 10

Order code	Description	Qty per pkg	Wt
		n°	[kg]

Digital meter for three phase with or without neutral.

DME D310 T2	Connection by CT /5A secondary, 2 programmable static outputs, 4U, multi-measurements ❶, expandable	1	0.332
-------------	---	---	-------

Order code	Description
------------	-------------

DME D310 T2 EXPANSION MODULES.

Inputs and outputs.

EXM10 00	2 digital inputs and 2 static outputs, opto-isolated
EXM10 01	2 opto-isolated digital inputs and 2 relay outputs rated 5A 250VAC

Communication ports.

EXM10 10	Opto-isolated USB interface
EXM10 11	Opto-isolated RS232 interface
EXM10 12	Opto-isolated RS485 interface
EXM10 13	Ethernet interface with Web server function
EXM10 20	Opto-isolated RS485 interface and 2 relay outputs rated 5A 250VAC
EXM10 30	Data storage, clock-calendar (RTC) with backup reserve energy for data logging

Maximum combination

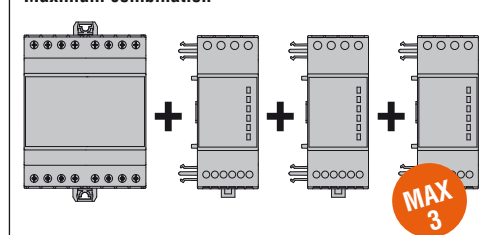

General characteristics

The energy meters are digital meters/analyzers of electric energy for systems with direct three-phase connection or by CT.

Expandable with up to 3 EXM series interfaced by infrared beam.

Operational characteristics

- Nominal supply voltage:
 - 380...415VAC (L-L) for DME D300 T2, DME D310 T2, DME D330 and DME D305
 - 190...415VAC (L-L) for DME D301
- Voltage range:
 - 323...456VAC (L-L) for DME D300 T2, DME D310 T2, DME D330 T2 and DME D305
 - 162...456VAC (L-L) for DME D301
- Direct connection 63A for DME D300 T2 and 80A for DME D301
- Connection by TA /5A or 1A for DME D310 T2, DME D330 and DME D305 T2
- Active energy measurement and accuracy: Class 0,5s (IEC/EN 62053-22) for DME D301 and DME D305 T2, Class 1 (IEC/EN 62053-21) for other types.
- Active energy measurement and accuracy: Class 2 (IEC/EN 62053-23)
- LCD multifunction meter
- Metrological LED with pulse emission for consumption indication
- Clearable partial active energy measurements
- 1 programmable digital input
- 2 programmable static outputs except DME D330 and DME D301
- Built-in RS485 port for DME D330 and DME D301 and optional for DME D310 T2; compatible with **Synergy** and **Xpress**
- Optic interface for EXM10... expansion modules with DME D310 T2
- Modular housing, 4 module
- Sealable terminal blocks, standard supplied
- Degree of protection: IP40 on front; IP20 at terminals.

Synergy supervision and energy management software
See page 16-22.

Xpress configuration and remote control software
See page 16-25.

EXM series expansion modules
See page 16-16.

Certifications and compliance

Certifications obtained: EAC.

Compliant with standards: EN 50740-3, IEC/EN 61010-1.

❶ Multi-measurements:

- Total and partial active energy
- Total and partial reactive energy
- Voltage
- Current
- Active and reactive power
- Power factor
- Frequency
- Total and partial hour counter
- Average active power (calculation on every last 15 minutes)
- Maximum demand.

Expandable



DME CD - DME CD PV1



EXM10 10

Order code	Description	Qty per pkg	Wt
		n°	[kg]
Data concentrator for general use.			
DME CD	With 8 programmable digital inputs, expandable, for data collection + pulse count from DMEM100T1 and DME D..., RS485 port	1	0.337
Data concentrator for photovoltaic applications.			
DME CD PV1	Programmed for installation control and data collection+pulse count from two DMED minimum, RS485 port, expandable	1	0.340

ⓘ Except DME D100 T1.

Order code	Description
DME CD AND DME CD PV1 EXPANSION MODULES. Inputs and outputs.	
EXM10 00	2 digital inputs and 2 static outputs, opto-isolated
EXM10 01	2 opto-isolated digital inputs and 2 relay outputs rated 5A 250VAC
EXM10 02	4 opto-isolated digital inputs and 2 relay outputs rated 5A 250VAC
Communication ports.	
EXM10 10	Opto-isolated USB interface
EXM10 11	Opto-isolated RS232 interface
EXM10 12	Opto-isolated RS485 interface
EXM10 13	Ethernet interface with Web server function
EXM10 20	Opto-isolated RS485 interface and 2 relay outputs, rated 5A 250VAC
EXM10 30	Data storage, clock-calendar (RTC) with backup reserve energy for data logging

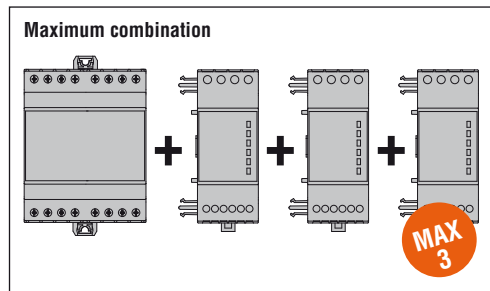

General characteristics

DME CD is equipped with 8 inputs, which can be increased up to a maximum of 14 and allows to indirectly interface devices without communication as long as they have at least one pulse output.

It is capable of pulse counting that come in from the outputs of meters for energy, water, gas and other types of consumption: All data is viewed on its display or can also be available for PCs through its built-in RS485 interface using **Synergy** or **Xpress** software.

It can be expanded with up to 3 EXM series modules by optic interface.

With the programmable functions, average values can be determined for instantaneous quantities, such as power, speed, production rate, gas and water consumption, etc.

DME CD PV1 is specific for the monitoring of solar installations and needs to be connected to at least two DME D... meters (single or three phase). The user can avail of data, such as energy produced by the generating installation, energy consumed by loads as well as exchanged energy (difference between import and export energy) with the power supplier.

It is already programmed to automatically calculate the self-consuming index and autonomy, mean power values, production (total and partial values) and the operating status of the AC/DC inverter, if it is equipped with digital outputs. In addition, it can be customised by the user for load supervision, using the EXM series expansion modules, according to the defined logics and on the basis of the energy available.

Operational characteristics

- Nominal supply voltage: 100...240VAC/110...250VDC
- Voltage range: 85...264VAC/93,5...300VDC
- Backlight graphic LCD
- 8 inputs, expandable with EXM 10... modules up to 14
- Built-in RS485 communication port
- Modbus-RTU, ASCII and TCP communication protocol
- Multifunction display
- Clearable total and partial counters for each channel
- Programmable general counters
- Calculation of derivative average values
- Mathematical operations among counters
- Modular housing, 4 module
- IEC degree of protection: IP40 on front; IP20 at terminals.

Synergy supervision and energy management software
See page 16-22.

Xpress configuration and remote control software
See page 16-25.

EXM series expansion modules
See page 16-16.

Certifications and compliance

Certifications obtained: cULus for DME CD; EAC for all.
Compliant with standards: IEC/EN 61010-1, IEC/EN 61000-6-2, IEC/EN 61000-6-3.

Modular LCD multimeters non expandable



DMG 1...



DMG 200 - DMG 210



Order code	Description	Qty per pkg.	Wt
		n°	[kg]
DMG 100	Icon LCD, auxiliary supply 100...240VAC/120...250VDC. Multilanguage: Italian, English, French, Spanish, Portuguese and German	1	0.294
DMG 101	Icon LCD, auxiliary supply 100...240VAC/120...250VDC. 2 digital inputs and 2 outputs. Multilanguage: Italian, English, French, Spanish, Portuguese and German	1	0.294
DMG 110	Icon LCD, RS485 port, auxiliary supply 100...240VAC/120...250VDC. Multilanguage: Italian, English, French, Spanish, Portuguese and German	1	0.294
DMG 200	Graphic 128x80 pixel LCD, auxiliary supply 100-240VAC/110-250VDC. Multilanguage: Italian, English, French, Spanish and Portuguese	1	0.294
DMG 210	Graphic 128x80 pixel LCD, RS485 port, auxiliary supply 100-240VAC/110-250VDC. Multilanguage: Italian, English, French, Spanish and Portuguese	1	0.300

General characteristics

DMG... digital multimeters are available with a modular housing, 4 module size, and are equipped with a graphic backlight LCD (except DMG 100/101/110 with icon display) capable of providing extremely clear, intuitive and flexible viewing of all electrical parameters of an installation. For DMG 110 and DMG 210 versions, there is a built-in isolated RS485 interface, while DMG 101 features 2 programmable digital inputs and 2 outputs.

Main measurements:

- Voltage: phase, line and system values
- Current: phase values (neutral current calculated)
- Power: apparent, active and reactive phase and total values
- P.F.: Power Factor per phase and total
- Frequency of measured voltage value
- HIGH-LOW-AVERAGE value functions of all measurements
- Maximum demand of power and current values
- asymmetric voltage and current
- Total harmonic distortion (THD) of voltage and current values
- Energy meters for active, reactive and apparent values
- hour counter (total and partial, 1 on DMG 200/210, 4 programmable on DMG 100/101/110)
- phase energy (DMG 100/110)
- harmonic analysis up to the 15th order (DMG 100/110).

Operational characteristic

- Auxiliary supply voltage range: 85...264VAC / 93,5...300VDC
- maximum rated measurement voltage
 - 600VAC (DMG 100/101/110)
 - 690VAC (DMG 200/210)
- Voltage measurement range:
 - 50...720VAC phase-to-phase (DMG 100/101/110)
 - 20...830VAC phase-to-phase (DMG 200/210)
- Usage in medium and high-voltage systems with voltage transformers
- Rated input current: With external CT /5A (also 1A for DMG 100/101/110)
- Current measurement range with CT up to 10,000A
- Frequency measurement range: 45-66Hz
- True RMS measurements for voltage and current values
- Accuracy:
 - Voltage: $\pm 0,5\%$ (50...720VAC for DMG 1...)
 - (50...830VAC) for DMG 2...
 - Current: $\pm 0,5\%$ (0,1...1,1In)
 - Power: $\pm 1\%$ f.s.
 - Frequency: $\pm 0,05\%$
 - Active energy: Class 1 (IEC/EN 62053-21)
 - Reactive energy: Class 2 (IEC/EN 62053-23)
- Non-volatile memory for data storage
- Communication protocol Modbus-RTU and ASCII (only for DMG 210 and DMG 110)
- Programming and remote control by software (only for DMG 210 and DMG 110; compatible with Synergy and Xpress software)
- Modular housing, 4 module
- Degree of protection: IP40 on front; IP20 at terminals.

CURRENT TRANSFORMERS OF DMG... KITS

- Operating frequency: 50...60Hz
- Secondary output current: 5A
- Overload withstand: 120% I_{pn}
- Rated insulation voltage U_i: 720V
- Rated short time thermal current I_{th}: 40...60I_{pn} for 1 second
- Rated dynamic current I_{dyn}: 2.5I_{th} for 1 second
- Insulation (dry type): class E
- Faston terminals
- Degree of protection: IP30.

Synergy supervision and energy management software
See page 16-22.

Xpress configuration and remote control software
See page 16-25.

Certifications and compliance

Certifications obtained: cULus, EAC.
Compliant with standards: IEC/EN 61010-1, IEC/EN 61000-6-2, IEC/EN 61000-6-4; UL61010-1, CSA C22.2 n° 61010-1 for DMG 100/110 (DMG 101 pending); UL508, CSA C22.2 n° 14 for DMG 200/210; IEC/EN 60044-1 for transformers of starter kits.

Starter kits



Order code	Description	Qty per pkg.	Wt
		n°	[kg]
DMG KIT 100 060	Composed of one DMG 100 multimeter and n°3 CTs 60/5A for Ø22mm cable	1	1.035
DMG KIT 100 100	Composed of one DMG 100 multimeter and n°3 CTs 100/5A for Ø22mm cable	1	1.035
DMG KIT 100 150	Composed of one DMG 100 multimeter and n°3 CTs 150/5A for Ø23mm cable	1	0.856
DMG KIT 100 250	Composed of one DMG 100 multimeter and n°3 CTs 200/5A for Ø23mm cable	1	0.856

DMG KIT 100 150

Modular LCD multimeters expandable



DMG 300



EXM10 10

Order code	Description	Qty per pkg	Wt [kg]
DMG 300	Graphic 128x80 pixel LCD, harmonic analysis, auxiliary supply 100-240VAC/110-250VDC, expandable with modules series EXM... Multilanguage: Italian, English, French, Spanish and Portuguese	1	0.320

Order code	Description
DMG 300 AND DMG 300 L01 EXPANSION MODULES. Inputs and outputs.	
EXM10 00	2 digital inputs and 2 static outputs, opto-isolated
EXM10 01	2 opto-isolated digital inputs and 2 relay outputs rated 5A 250VAC
EXM10 02	4 opto-isolated digital inputs and 2 relay outputs rated 5A 250VAC
Communication ports.	
EXM10 10	Opto-isolated USB interface
EXM10 11	Opto-isolated RS232 interface
EXM10 12	Opto-isolated RS485 interface
EXM10 13	Ethernet interface with Web server function
EXM10 20	Opto-isolated RS485 interface and 2 relay outputs rated 5A 250VAC
EXM10 30	Data storage, clock-calendar (RTC) with backup battery for data logging

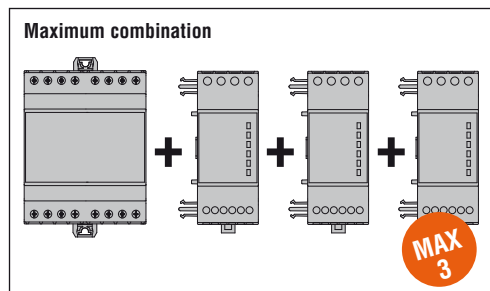

General characteristics

DMG 300 digital multimeters are available with a modular housing, 4 module size, and are equipped with a graphic backlight LCD capable of providing extremely clear, intuitive and flexible viewing of all electrical parameters of a system. The very accurate measurements combined with their extreme compactness provide an ideal solution for every type of application.

Expandable with up to 3 EXM series modules interfaced by infrared beam.

Main measurements:

- Voltage: phase, line and system values
- Current: phase values (neutral current calculated)
- Power: apparent, active and reactive phase and total values
- P.F.: Power Factor per phase and total
- Frequency of measured voltage value
- HIGH-LOW-AVERAGE value functions for all measurements
- Maximum demand of power and current values
- Voltage and current asymmetry
- Total harmonic distortion (THD) of voltage and current values
- Harmonic analysis of voltage and current up to 31° order
- Energy meters for active, reactive, apparent partial and total values, programmable tariff functions
- Hour counter for programmable total and partial hours
- Pulse counter for general use: consumption pulse counting for water, gas, etc. with expansion module only.

Operational characteristics

- Auxiliary supply voltage range: 85...264VAC / 93.5...300VDC
- Voltage measurement range: 20...830VAC phase-to-phase / 10...480VAC phase-neutral
- Usage in medium and high-voltage systems with voltage transformers
- Rated input current: With external CT, 5A or 1A
- Current measurement range with CT up to 10,000A
- Frequency measurement range: 45-66Hz
- True RMS measurements for voltage and current values
- Accuracy:
 - Voltage: $\pm 0.2\%$ (50-830VAC)
 - Current: $\pm 0.2\%$ (0.1-1.1 In)
 - Power: $\pm 0.5\%$ f.s.
 - Power factor: $\pm 0.5\%$
 - Frequency: 0.05%
- Active energy: Class 0.5S (IEC/EN 62053-22)
- Reactive energy: Class 2 (IEC/EN 62053-23)
- Non-volatile memory for data storage
- Communication protocol Modbus-RTU, ASCII and TCP (only with communication expansion modules)
- Programming and remote control by software (only with communication expansion modules); compatible with **Synergy** and **Xpress** software
- Modular housing, 4 module
- Degree of protection: IP40 on front; IP20 at terminals.

Synergy supervision and energy management software
See page 16-22.

Xpress configuration and remote control software
See page 16-25.

EXM10 series expansion modules
See page 16-16.

Certifications and compliance

Certifications obtained: cULus, EAC.
Compliant with standards: IEC/EN 61010-1, IEC/EN 61000-6-2, IEC/EN 61000-6-4, UL508, CSA C22.2 n° 14.

Flush mount LCD multimeters, expandable



DMG 600 - DMG 610



DMG 700 - DMG 800...



DMG M3 800 01



EXP10...

Order code	Description	Qty per pkg	Wt [kg]
DMG 600	Backlight icon LCD 72x46mm harmonic analysis, auxiliary supply 100...440VAC/120...250VDC, front optical port. Multilanguage: Italian, English, French, Spanish, Portuguese and German.	1	0.300
DMG 610	Backlight icon 72x46mm harmonic analysis, auxiliary supply 100...440VAC/120...250VDC, built-in RS485 front optical serial port. Multilanguage: Italian, English, French, Spanish, Portuguese and German	1	0.350
DMG 700	Graphic 128x80 pixel LCD, auxiliary supply 100...440VAC/110...250VDC Multilanguage: Italian, English, French, Spanish and Portuguese	1	0.510
DMG 800	Graphic 128x80 pixel LCD, harmonic analysis, auxiliary supply 100...440VAC/110...250VDC Multilanguage: Italian, English, French, Spanish and Portuguese	1	0.510
DMG 800 D048	Graphic 128x80 pixel LCD, harmonic analysis, auxiliary supply 12-24-48VDC	1	0.520
DMG M3 800 01	DMG 800 portable unit in M3N case, prewired, for mobile applications, with USB port, without external cable (see p. 16-18)	1	3.300

Order code	Description
DMG600/610, DMG700, DMG800 EXPANSION MODULES Inputs and outputs.	
EXP10 00	4 opto-isolated digital inputs
EXP10 01	4 opto-isolated static outputs
EXP10 02	2 digital inputs and 2 static outputs, opto-isolated
EXP10 03	2 relay outputs rated 5A 250VAC
EXP10 04	2 opto-isolated analog inputs 0/4-20mA or PT100 or 0-10V or 0...±5V for DMG 800
EXP10 05	2 opto-isolated analog outputs 0/4-20mA or 0-10V or 0...±5V for DMG 800
EXP10 08	2 opto-isolated digital inputs and 2 relay outputs rated 5A 250VAC
Communication ports.	
EXP10 10	Opto-isolated USB interface
EXP10 11	Opto-isolated RS232 interface
EXP10 12	Opto-isolated RS485 interface
EXP10 13	Opto-isolated Ethernet interface with web server function
EXP10 14	Opto-isolated Profibus-DP interface for DMG 800
EXP10 30	Data storage, clock-calendar (RTC) with backup reserve energy for data logging for DMG 800

General characteristics

DMG 600/610, DMG 700 and DMG 800 digital multimeters are capable of viewing the measurements with high accuracy on the wide graphic LCD, which allow to control energy distribution networks. They are available with a flush-mount housing, (96x96mm/3.78"x3.78") and expansion slots to fit plug-in expansion modules (1 for DMG 600/610 and 4 for DMG 700/800), suitable for numerous applications. The main features include an extended power supply voltage range, high measurement accuracy, expandability and graphic interactive interface for simple use.

Main measurements:

- Voltage: phase, line and system values
- Current: phase values (neutral current calculated)
- Power: apparent, active and reactive phase and total values
- P.F.: Power Factor per phase and total
- Frequency of measured voltage value
- HIGH-LOW-AVERAGE value functions for all measurements
- Maximum demand of power and current values
- Voltage and current asymmetry
- Total harmonic distortion (THD): voltage and current
- Harmonic analysis of voltage and current up to the 15° (DMG 600/610) and 31° order (only DMG 800)
- Energy meters for active, reactive, apparent partial and total values
- programmable tariff functions (only DMG 700/800)
- Hour counter for programmable total and partial hours
- Pulse counter for general use: consumption pulse counting for water, gas, etc., with expansion module only DMG 700/800.

Operational characteristics

- Auxiliary supply voltage range:
 - 90...484VAC / 93.5...300VDC per DMG 600/610/700/800
 - 9...70VDC per DMG 800 D048
- Voltage measurement range:
 - 20...830VAC L-L / per DMG 700/800
 - 50...720VAC L-L per DMG 600/610
- Usage in medium and high voltage systems with voltage transformers
- Rated input current: By external CT 5A for DMG 700; By external CT 5A or 1A for DMG 600/610, DMG 800
- Frequency measurement range 45...66Hz
- True RMS measurements: for voltage and current
- Measurement accuracy for DMG 600/610-DMG 700:
 - Voltage: ±0,5% (50...720VAC per DMG 600/610; 50...830VAC per DMG 700)
 - Current: ±0,5% (0,1...1,1n)
 - Power: ±1% f.s.
 - Frequency: ±0,05%
 - Active energy: Classe 1 (IEC/EN 62053-21)
 - Reactive energy: Class 2 (IEC/EN 62053-23)
- Measurement accuracy for DMG 800...:
 - Voltage: ±0,2% (50...830VAC)
 - Current: ±0,2% (0,1...1,1n)
 - Power: ±0,5% f.s.
 - Power factor: ±0,5%
 - Frequency: ±0,05%
 - Active energy: Class 0,5s (IEC/EN 62053-22)
 - Reactive energy: Class 2 (IEC/EN 62053-23)
- Non-volatile memory for data storage
- Communication protocol Modbus-RTU, ASCII and TCP
- Compatible with **Synergy** and **Xpress** software
- Flush-mount housing 96x96mm/3.78"x3.78"
- Degree of protection: On front IP54 DMG 600/610; IP65 all others. All IP20 at terminals.

Overall M3N case dimensions: 280h x 220w x 170d mm.

Synergy supervision and energy management software
See page 16-22.

Xpress configuration and remote control software
See page 16-25.

EXP series expansion modules
See page 16-15.

Certifications and compliance

Certifications obtained: cULus, EAC (except DMG M3...)
Compliant with standards: IEC/EN61010-1, IEC/EN61000-6-2, IEC/EN61000-6-3, UL508, CSA C22.2 n° 14. For DMG 600/610 UL610-1, CSA C22.2 n° 61010-1.

Flush mount LCD touchscreen power analysers, expandable



DMG 900...



DMG M3 900 01



DMG 900T...



DMG 900RD



EXP10...

Order code	Description	Qty per pkg.	Wt [kg]
DMG 900	Graphic 128x112 pixel touch-screen LCD, harmonic analysis, 4 current channels, (neutral meas.), 100...440VAC/110...250VDC. Multilanguage: Italian, English, French, Spanish and Portuguese	1	0.566
DMG 900 D048	Graphic 128x112 pixel touch-screen LCD, harmonic analysis, 4 current channels, auxiliary supply 12-24-48VDC	1	0.580
DMG M3 900 01	DMG 900 portable unit in M3N case, prewired for mobile applications, with USB port, without external cables (see page 16-18).	1	3.400
DMG 900T	Measurement transducer, harmonic analysis, 4 current channels (neutral meas.), 100...440VAC/110...250VDC, RS232 and RS485 ports ①	1	0.570
DMG 900T D048	Measurement transducer, harmonic analysis, 4 current channels (neutral meas.), 12-24-48VDC, RS232 and RS485 ports ①	1	0.590
Remote display for DMG 900T...			
DMG 900RD	Graphic 128x112 pixel touch screen LCD, with 3m long connecting cable②	1	0.396

- ① No simultaneous operations of serial ports. Consult Customer Service for information (Tel. 1800 252 995) or the instructions manual.
- ② Direct link to DMG 900T dedicated port: powered directly by DMG 900T.

Order code	Description
DMG 900 and DMG 900 T EXPANSION MODULES. Inputs and outputs.	
EXP10 00	4 opto-isolated digital inputs
EXP10 01	4 opto-isolated static outputs
EXP10 02	2 digital inputs and 2 static outputs, opto-isolated
EXP10 03	2 relay outputs rated 5A 250VAC
EXP10 04	2 opto-isolated analog inputs 0/4-20mA or PT100 or 0-10V or 0...±5V
EXP10 05	2 opto-isolated analog outputs 0/4-20mA or 0-10V or 0...±5V
EXP10 08	2 opto-isolated digital inputs and 2 relay outputs rated 5A 250VAC
Communication ports.	
EXP10 10	Opto-isolated USB interface
EXP10 11	Opto-isolated RS232 interface
EXP10 12	Opto-isolated RS485 interface
EXP10 13	Opto-isolated Ethernet interface with Web server function
EXP10 14	Opto-isolated Profibus-DP interface
EXP10 30	Data storage, clock-calendar (RTC) with backup reserve energy for data logging
EXP10 31	Data storage, with Energy Quality (EN 50160 - class B), clock-calendar (RTC) with backup reserve energy for data logging

General characteristics

DMG 900... expandable digital power analyzers are available with a flush-mount housing, 96x96mm/3.78"x3.78". The wide graphic touch screen display provides extremely simple interacting between the device and the user. The high performance of the power analyzers gives very accurate measurements and can control energy distribution networks, to detect and prevent energy problems which could compromise quality and supply. The main features include an extensive power supply voltage range, high measurement accuracy, expandability up to 4 plug in expansion modules. There also is available the DMG 900T measurement transducer which can be used with the DMG 900RD remote display. The DMG 900T, without display, is arranged for mounting inside the panel board, on 35mm DIN rail, and is an ideal solution for installations where the measurements of various multimeters must be remotely viewed. The DMG 900RD remote display connected to the DMG 900T transducer can display the measurements on the panel front while power connections remain inside the panel. Main measurements and functions include:

- Voltage: phase, phase-neutral and ground neutral-earth
- Supply voltage value (only DMG... D048)
- Current: phase values
- Neutral current calculated and true values
- Power: apparent, active and reactive phase and total values
- P.F.: Power Factor per phase and total
- Cosφ per phase and total
- Frequency of measured voltage value
- Voltage and current asymmetry
- Total harmonic distortion (THD) of voltage and current
- Harmonic analysis of voltage and current up to the 63° order
- HIGH-LOW-AVERAGE value functions for all measurements
- Maximum demand of power and current values
- Energy meters for active, reactive, apparent partial and total values with programmable tariff functions
- Hour counter for programmable total and partial hours
- Pulse counter for general use: consumption pulse counting for water, gas, etc., with expansion module only
- Energy quality analysis to EN 50160 Class B (with expansion module).

Operational characteristics

- Auxiliary supply voltage range: 90...484VAC / 93.5...300VDC for DMG 900 and DMG 900T; 9...70VDC for DMG 900 D048 and DMG 900T D048
- Voltage measurement range: 20...830VAC phase-to-phase 10...480VAC phase-neutral
- Usage in medium and high-voltage systems with voltage transformers
- rated input current: 5A or 1A via CT
- Current measurement range: 0,05...10A o 0,01...1.2A
- current measurements via CT up to 10,000A
- Frequency measurement range: 45...66Hz / 360...440Hz
- True RMS measurements for voltage and current values

Accuracy:

- Voltage: ±0,2% (50...830VAC)
- Current: ±0,2% (0.1...1.1n)
- Power: ±0,5% f.s.
- Power factor: ±0,5%
- Frequency: ±0,05%
- Active energy: Class 0.5s (IEC/EN 62053-22)
- Reactive energy: Class 2 (IEC/EN 62053-23)
- Non-volatile memory for data and event (last 100) storage
- Communication protocol Modbus-RTU, ASCII and TCP with communication expansion modules only
- Programming and remote control by software with communication expansion modules only
- housing: 96x96mm/3.78"x3.78" flush mount (for DMG 900... and DMG 900RD) and 35mm DIN rail (for DMG 900T...)
- Degree of protection: IP65 on front for DMG 900 - DMG 900RD; IP20 at terminals for DMG 900 - DMG 900T.

Synergy supervision and energy management software
See page 16-22.

Xpress configuration and remote control software
See page 16-25.

EXP series expansion modules - See page 16-15.

Certifications and compliance

Certifications obtained: cULus, EAC (except DMG M3). Compliant with standards: IEC/EN 61010-1, IEC/EN 61000-6-2, IEC/EN 61000-6-3, UL 508, CSA C22.2 n°14.

Flush-mount LED instruments single phase non expandable



DMK 0...

Order code	Displayed measurements	Output relay	Qty per pkg	Wt [kg]
	n°	n°	n°	[kg]
Voltmeter.				
DMK 00	1 voltage value	–	1	0.290
DMK 00 R1 ②	1 max voltage value 1 min voltage value	1	1	0.323
Ammeter.				
DMK 01	1 current value	–	1	0.290
DMK 01 R1 ②	1 max current value 1 min current value	1	1	0.323
Voltmeter or ammeter.				
DMK 02 ①	1 voltage or current value 1 maximum voltage or current value 1 minimum voltage or current value	–	1	0.290
Frequency meter.				
DMK 03	1 frequency value	–	1	0.290
DMK 03 R1 ②	1 max frequency value 1 min frequency value	1	1	0.323
Cosphi meter.				
DMK 04	1 cosphi value	–	1	0.290
DMK 04 R1 ②	1 power factor value	1	1	0.323

① The DMK02 can operate as a voltmeter or ammeter. It is duly equipped with two front plates (V and A) which must be fitted by the user depending on which instrument is required and on the wiring scheme used.

② Relay output for control and protection functions.

General characteristics

The DMK 0... instruments are available with flush-mount housing, 96x48mm/3.8x1.9in size. Measurements are True RMS values and provide for reliable operation even in presence of harmonics.

Operational characteristics

- Auxiliary supply voltage: 220-240VAC standard; 24VAC, 110-127VAC or 380-415AC type on request
- Operating frequency: 50-60Hz
- True RMS measurements
- HIGH and LOW measurement storage
- 1 relay output with 1 changeover contact (SPDT) for DMK...R1 only
- Housing: flush mount 96x48mm / 3.8x1.9in
- Terminals: 4mm²
- IEC protection degree: IP54 on front; IP20 at terminals.

DMK 00 - DMK 00 R1

- Voltage measurement range: 15-660VAC
- Operating frequency range: 45-65Hz
- Programmable VT ratio: 1.00-500.00
- Accuracy: $\pm 0.25\%$ f.s. ± 1 digit

DMK 01 - DMK 01 R1

- Current measurement range: 0.05-5.75A
- Operating frequency range: 45-65Hz
- Programmable CT ratio: 5-10,000
- Accuracy: $\pm 0.5\%$ f.s. ± 1 digit

DMK 02

- Voltage measurement range: 15-660VAC
- Current measurement range: 0.05-5.75A
- Operating frequency range: 45-65Hz
- Programmable VT ratio: 1.00-500.00
- Programmable CT ratio: OFF/5-10,000
- Accuracy: Voltage $\pm 0.25\%$ f.s. ± 1 digit
Current $\pm 0.5\%$ f.s. ± 1 digit

DMK 03 - DMK 03 R1

- Measurement input: 15-660VAC
- Frequency measurement range: 15-65Hz
- Accuracy: ± 1 digit

DMK 04 - DMK 04 R1

- Cosphi measurement error: $\pm 0.5^\circ \pm 1$ digit
- Cosphi measurement in 4 quadrants
- Accuracy: $\pm 1^\circ \pm 1$ digit

Control and protection functions

DMK 00 R1

- Voltage loss or failure: OFF/5-85%
- Maximum voltage: OFF/102-120%
- Minimum voltage: OFF/70-98%
- Time delay for max-min voltage or voltage loss, phase loss ③: 0.0-900.0 seconds.

DMK 01 R1

- Current loss: OFF/2-100%
- Maximum current: OFF/102-200%
- Maximum current instantaneous tripping: OFF/110-600%
- Minimum current: OFF/5-98%
- Time delay for max-min current or current loss ③: 0.0-900.0 seconds.

DMK 03 R1

- Maximum frequency: OFF/101-110%
- Minimum frequency: OFF/90-99%
- Time delay for min-max frequency ③: 0.5-900.0 seconds.

DMK 04 R1

- Minimum-maximum $\cos\phi$ thresholds in 4 quadrants
- Minimum-maximum PF thresholds in 4 quadrants
- Delay time for max or min threshold ③: 1-9,000 seconds.

Certifications and compliance

Certifications obtained: GOST and UL Listed, for USA and Canada (File E93601), as Auxiliary Devices-Multimeter. Compliant with standards: IEC/EN 61010-1, IEC/EN 61000-6-2, IEC/EN 61000-6-3, UL 508, CSA C22.2 n° 14.

For dimensions refer to page 16-31.

③ Independent adjustable delays.

Flush-mount LED instruments three phase non expandable



DMK 1...

Order code	Displayd measurements	Output relay	Qty per pkg	Wt [kg]
	n°	n°	n°	[kg]
Voltmeter.				
DMK 10	3 phase voltage values	–	1	0.297
DMK 10 R1 ②	3 phase to phase voltage values 3 maximum phase voltage values 3 maximum phase to phase voltage values 3 minimum phase voltage values 3 minimum phase to phase voltage values	1	1	0.330
Ammeter.				
DMK 11	3 phase current values	–	1	0.292
DMK 11 R1 ②	3 maximum phase current values 3 minimum phase current values	1	1	0.336
Combined voltmeter, ammeter and wattmeter.				
DMK 15	3 phase voltage values	–	1	0.332
DMK 15 R1 ①②	3 phase to phase voltage values 3 phase current values 4 active power values, phase and total 3 maximum phase voltage values 3 maximum phase to phase voltage values 3 maximum phase current values 4 maximum active power values, phase and total 3 minimum phase voltage values 3 minimum phase to phase voltage values 3 minimum phase current values 4 minimum active power values, phase and total	1	1	0.350

① Connection also to single phase.

② Relay output for control and protection functions.

General characteristics

The DMK 1... instruments are available with flush-mount housing, 96x48mm/3.8x1.9in size. Measurements are TRMS values and provide for reliable operation even in presence of harmonics.

Operational characteristics

- Auxiliary supply voltage: 220-240VAC standard; 24VAC, 110-127VAC or 380-415VAC type on request
- Operating frequency: 50-60Hz
- TRMS measurements
- HIGH and LOW measurement storage
- 1 relay output with 1 changeover contact (SPDT) for DMK...R1 only
- Housing: flush mount 96x48mm / 3.8x1.9in
- Terminals: 4mm²
- IEC protection degree: IP54 on front; IP20 at terminals.

DMK 10 - DMK 10 R1

- Voltage measurement range: 15-660VAC
- Operating frequency range: 45-65Hz
- Programmable VT ratio: 1.00-500.00
- Accuracy: $\pm 0.25\%$ f.s. ± 1 digit.

DMK 11 - DMK 11 R1

- Current measurement range: 0.05-5.75A
- Operating frequency range: 45-65Hz
- Programmable CT ratio: 5-10,000
- Accuracy: $\pm 0.5\%$ f.s. ± 1 digit.

DMK 15 - DMK 15 R1

- Voltage measurement range: 35-660VAC
- Current measurement range: 0.05-5.75A
- Frequency measure range: 45-65Hz
- Programmable VT ratio: 1.00-500.00
- Programmable CT ratio: 5-10,000
- Accuracy: Voltage $\pm 0.25\%$ f.s. ± 1 digit
Current $\pm 0.5\%$ f.s. ± 1 digit
Power $\pm 1\%$ f.s. ± 1 digit.

Control and protection functions

DMK 10 R1

- Phase loss or failure: OFF/5-85%
- Maximum voltage: OFF/102-120%
- Minimum voltage: OFF/70-98%
- Asymmetry: OFF/2-20%
- Phase sequence: OFF/L1-L2-L3/L3-L2-L1
- Frequency
 - Maximum frequency: OFF/101-110%
 - Minimum frequency: OFF/90-99%
- Time delay for max-min voltage, phase loss, asymmetry and min-max frequency Ⓢ: 0.5-900.0 seconds.

DMK 11 R1

- Current loss: OFF/2-100%
- Maximum current: OFF/102-200%
- Maximum current instantaneous tripping: OFF/110-600%
- Minimum current: OFF/5-98%
- Asymmetry: OFF/2-20%
- Time delay for max-min current or current loss and asymmetry Ⓢ: 0.5-900.0 seconds.

DMK 15 R1

- Voltage
 - Phase loss or failure: OFF/5-85%
 - Maximum voltage: OFF/102-120%
 - Minimum voltage: OFF/70-98%
 - Asymmetry: OFF/2-20%
 - Phase sequence: OFF/L1-L2-L3/L3-L2-L1
- Current
 - Current loss: OFF/5-85%
 - Maximum current: OFF/102-200%
 - Maximum current instantaneous tripping: OFF/110-600%
 - Minimum current: OFF/5-98%
 - Asymmetry: OFF/2-20%
- Power
 - Rated power: 1-10,000
 - Maximum power: OFF/101-200%
 - Max. power instantaneous tripping: OFF/110-600%
 - Minimum power: OFF/10-99%
- Frequency
 - Maximum frequency: OFF/101-110%
 - Minimum frequency OFF/90-99%
- Time delay for max-min voltage, max-min current or current loss, phase loss, asymmetry and min-max power Ⓢ: 0.0-900.0 seconds.

Certifications and compliance

Certifications obtained: GOST and UL Listed, for USA and Canada (File E93601), as Auxiliary Devices-Multimeter.

Compliant with standards: IEC/EN 61010-1, IEC/EN 61000-6-2, IEC/EN 61000-6-3, UL 508, CSA C22.2 n° 14.

For dimensions refer to page 16-31.

Ⓢ Independent adjustable delays.

Flush-mount LED multimeter three phase non expandable



DMK 16

Order code	Displayed measurements	Qty per pkg	Wt
		n°	[kg]
DMK 16	3 phase voltage values 3 phase to phase voltage values 3 phase current values 4 active power values, phase and total 4 reactive power values, phase and total 4 apparent power values, phase and total 3 phase power factor values 1 frequency value 1 active energy value in kWh 1 reactive energy value in kvarh 1 hour counter 3 maximum phase voltage values 3 maximum phase to phase voltage values 3 maximum phase current values 4 maximum active power values, phase and total 4 maximum reactive power values, phase and total 4 maximum apparent power values, phase and total 3 minimum phase voltage values 3 minimum phase to phase voltage values 3 minimum phase current values 4 minimum active power values, phase and total 4 minimum reactive power values, phase and total 4 minimum apparent power values, phase and total	1	0.350

General characteristics

The DMK 16 multimeter is available with flush-mount housing, 96x48mm/3.8x1.9in size. Measurements are True RMS values and provide for reliable operation even in presence of harmonics.

Operational characteristics

- Auxiliary supply voltage: 220-240VAC standard; 24VAC, 110-127VAC or 380-415VAC type on request
- Operating frequency: 50-60Hz
- True RMS measurements
- Accuracy: Voltage $\pm 0.25\%$ f.s. ± 1 digit
Current $\pm 0.5\%$ f.s. ± 1 digit
- Active energy accuracy: Class 2 (IEC/EN 62053-21 and IEC/EN 62053-23)
- HIGH and LOW measurement storage
- Voltage measurement range: 35-660VAC
- Current measurement range: 0.05-5.75A
- Operating frequency range: 45-65Hz
- Programmable VT ratio: 1.00-500.0
- Programmable CT ratio: 5-10,000
- Housing: flush mount 96x48mm / 3.8x1.9in
- Terminals: 4mm²
- IEC protection degree: IP54 on front; IP20 at terminals.

Certifications and compliance

Certifications obtained: GOST and UL Listed, for USA and Canada (File E93601), as Auxiliary Devices-Multimeter. Compliant with standards: IEC/EN 61010-1, IEC/EN 61000-6-2, IEC/EN 61000-6-3, UL508, CSA C22.2 n° 14.

For dimensions refer to page 16-31.

Flush-mount LED multimeter three phase non expandable



DMK 16 R1

Order code	Displayed measurements	Output relay	Qty per pkg	Wt [kg]
	n°	n°	n°	[kg]
DMK 16 R1 ①	3 phase voltage values 3 phase to phase voltage values 3 phase current values 4 active power values, phase and total 4 reactive power values, phase and total 4 apparent power values, phase and total 3 phase power factor values 1 frequency value 1 active energy value in kWh 1 reactive energy value in kvarh 1 hour counter 3 maximum phase voltage values 3 maximum phase to phase voltage values 3 maximum phase current values 4 minimum and maximum active power values, phase and total 4 minimum and maximum reactive power values, phase and total 4 minimum and maximum apparent power values, phase and total 2 minimum and maximum power factor values	1	1	0.353

① Connection also to single phase.

General characteristics

The DMK 16 R1 multimeter is available with flush-mount housing, 96x48mm/3.8x1.9in size. Measurements are True RMS values and provide for reliable operation even in presence of harmonics.

Operational characteristics

- Auxiliary supply voltage: 220-240VAC standard; 24VAC, 110-127VAC or 380-415VAC type on request
- Operating frequency: 50-60Hz
- True RMS measurements
- Accuracy: Voltage $\pm 0.25\%$ f.s. ± 1 digit
Current $\pm 0.5\%$ f.s. ± 1 digit
- Active energy accuracy: Class 2 (IEC/EN 62053-21 and IEC/EN 62053-23)
- HIGH and LOW measurement storage
- Voltage measurement range: 35-660VAC
- Current measurement range: 0.05-5.75A
- Frequency measurement range: 45-65Hz
- Programmable VT ratio: 1.00-500.0
- Programmable CT ratio: 5-10,000
- 1 relay output with 1 changeover (SPDT) contact
- Housing: flush mount 96x48mm / 3.8x1.9in
- Terminals: 4mm²
- IEC protection degree: IP54 on front; IP20 at terminals.

PROGRAMMABLE RELAY OUTPUT

- Voltage
 - Phase loss or failure: OFF/5-85%
 - Maximum voltage: OFF/102-120%
 - Minimum voltage: OFF/70-98%
 - Asymmetry: OFF/2-20%
 - Phase sequence: OFF/L1-L2-L3/L3-L2-L1
- Current
 - Protection inhibition max current: OFF/2-100%
 - Maximum current: OFF/102-200%
 - Maximum current instantaneous tripping: OFF/110-600%
 - Minimum current: OFF/5-98%
 - Asymmetry: OFF/2-20%
- Power factor
 - Maximum power factor: 0.10-1.00
 - Minimum power factor: 0.10-1.00
- Time delay for max-min voltage, max-min current or current loss, phase loss, asymmetry and min-max power factor ⌚: 0.0-900.0 seconds.

Certifications and compliance

Certifications obtained: GOST; UL Listed, for USA and Canada (File E93601), as Auxiliary Devices-Multimeter. Compliant with standards: IEC/EN 61010-1, IEC/EN 61000-6-2, IEC/EN 61000-6-3, UL 508, CSA C22.2 n° 14.

For dimensions refer to page 16-31.

⌚ Independent adjustable delays.

Flush mount LED multimeters non expandable 47 electrical parameters



DMK 2...

Order code	Description	Qty per pkg.	Wt
		n°	[kg]
DMK 20	Basic version, auxiliary supply 208...240VAC	1	0.434
DMK 21	Version with energy meters included, auxiliary supply 208...240VAC	1	0.477
DMK 22	Version with energy meters and RS485 port included, auxiliary supply 208...240VAC	1	0.477

General characteristics

DMK 2... digital multimeters are available with flush-mount housing, 96x96mm/3.78x3.78". They monitor and view reliable readings of electrical parameters, even in presence of critical operating conditions, such as voltages and currents with high harmonic content and variable frequency. The total and partial hour counter feature provides an interesting feature for electric panels of emergency generating sets.

The diversified and accurate measurements give the multimeters valuable technical and cost effective advantages respect to traditional analog instrumentation.

DMK2... digital multimeters view 47 electrical parameters:

- Voltage: phase, line and system values
- Current: phase values
- Power: active and reactive values, apparent phase.
- P.F.: power factor per phase
- Frequency (measured voltage frequency)
- HIGH/LOW: instantaneous minimum and maximum values of each phase voltage and current, total active power (ΣW), total reactive power (Σvar) and total apparent power (ΣVA) values
- Total hours: non-volatile clearable log for DMK 20
- Partial hours: non-volatile configurable log for DMK 20
- Active and reactive energy meters for DMK21 and DMK22 only.

Operational characteristics

- Auxiliary supply voltage range:
 - 154-288VAC for DMK 20
 - 177-264VAC for DMK 21-DMK 22
- Voltage measurement range: 60-830VAC phase-phase
30-480VAC phase-neutral
- Current measurement range: 0.05-6A
- Frequency measurement range: 45-65Hz
- Programmable CT ratio: 1.0-2.000
- Voltage accuracy: Class 0.5 $\pm 0.35\%$ f.s. (830V)
- Current accuracy: Class 0.5 $\pm 0.5\%$ f.s. (6A)
- Active energy accuracy: Class 2
- total and partial hour counter (can be used as maintenance with optical alarm and separate resetting) (DMK 20)
- HIGH and LOW value functions to read and log instantaneous voltage, current and power values
- Delayed automatic resetting of default measurements
- Averaging function to slow down repetitive fluctuations to obtain more stable readings
- Current connection in ARON configuration by 2 current transformers (CTs) only
- Single, two, three phase, with or without neutral,
- TRMS measurements
- RS485 serial port, compatible with **Synergy** software for DMK 22
- Housing: Flush mount 96x96mm/3.78x3.78"
- Degree of protection: IP54 on front; IP20 at terminals.

Synergy supervision and energy management software
See page 16-22.

Certifications and compliance

Certifications obtained: cULus, EAC.
Compliant with standards: IEC/EN 61010-1, IEC/EN 61000-6-2, IEC/EN 61000-6-3, UL508, CSA C22.2 n°14.

For dimensions refer to page 16-31.

Modular LED instruments single phase non expandable



DMK 80



DMK 80 R1



DMK 81



DMK 81 R1



DMK 82



DMK 82



DMK 83



DMK 83 R1



DMK 84



DMK 84 R1

Order code	Displayed measurements	Output relay	Qty per pkg	Wt [kg]
	n°	n°	n°	[kg]
Voltmeter.				
DMK 80	1 voltage value	-	1	0.237
DMK 80 R1	1 max voltage value 1 min voltage value	1	1	0.268
Ammeter.				
DMK 81	1 current value	-	1	0.237
DMK 81 R1	1 max current value 1 min current value	1	1	0.268
Voltmeter or ammeter.				
DMK 82	1 voltage or current value 1 maximum voltage or current value 1 minimum voltage or current value	-	1	0.241
Frequency meter.				
DMK 83	1 frequency value	-	1	0.237
DMK 83 R1	1 max frequency value 1 min frequency value	1	1	0.268
Cosphi meter.				
DMK 84	1 cosphi value	-	1	0.241
DMK 84 R1	1 power factor value	1	1	0.272

① The DMK82 can operate as a voltmeter or ammeter. It is duly equipped with two front plates (V and A) which must be fitted by the user depending on which instrument is required and on the wiring scheme used.

② Relay output with control and protection functions.

General characteristics

The DMK 8... instruments are available with modular housing, 3-module size.

Measurements are True RMS values and provide for reliable operation even in presence of harmonics.

Operational characteristics

- Auxiliary supply voltage: 220-240VAC standard; 24VAC, 110-127VAC or 380-415VAC type on request
- Operating frequency: 50-60Hz
- True RMS measurements
- HIGH and LOW measurement storage
- 1 output relay with 1 changeover contact for DMK...R1 version only
- Terminals: 4mm²
- Modular DIN 43880 housing, 3 modules
- Degree of protection: IP40 on front; IP20 on terminals.

DMK 80 - DMK 80 R1

- Voltage measurement range: 15-660VAC
- Operating frequency range: 45-65Hz
- Programmable VT ratio: 1.00-500.00
- Accuracy: $\pm 0.25\%$ f.s. ± 1 digit

DMK 81 - DMK 81 R1

- Current measurement range: 0.05-5.75A
- Operating frequency range: 45-65Hz
- Programmable CT ratio: 5-10,000
- Accuracy: $\pm 0.5\%$ f.s. ± 1 digit

DMK 82

- Voltage measurement range: 15-660VAC
- Current measurement range: 0.05-5.75A
- Operating frequency range: 45-65Hz
- Programmable VT ratio: 1.00-500.00
- Programmable CT ratio: OFF/5-10,000
- Accuracy: Voltage $\pm 0.25\%$ f.s. ± 1 digit
Current $\pm 0.5\%$ f.s. ± 1 digit

DMK 83 - DMK 83 R1

- Measurement input: 15-660VAC
- Frequency measurement range: 50-60Hz $\pm 10\%$
- Measurement accuracy: ± 1 digit
- Accuracy: $1^\circ \pm 1$ digit

DMK 84 - DMK 84 R1

- Cosphi measurement error: $\pm 0.5^\circ \pm 1$ digit
- Cosphi measurement in 4 quadrants
- Accuracy: $\pm 1^\circ$ digit

Control and protection functions

DMK 80 R1

- Voltage loss or failure: OFF/5-85%
- Maximum voltage: OFF/102-120%
- Minimum voltage: OFF/70-98%
- Time delay for max-min voltage or voltage loss, phase loss: 0.0-900.0 seconds.

DMK 81 R1

- Current loss: OFF/2-100%
- Maximum current: OFF/102-200%
- Maximum current instantaneous tripping: OFF/110-600%
- Minimum current: OFF/5-98%
- Time delay for max-min current or current loss: 0.0-900.0 seconds.

DMK 83 R1

- Maximum frequency: OFF/101-110%
- Minimum frequency: OFF/90-99%
- Time delay for min-max frequency: 0.5-900.0 seconds.

DMK 84 R1

- Minimum-maximum $\cos\phi$ thresholds in 4 quadrants
- Minimum-maximum PF thresholds in 4 quadrants
- Delay time for max or min threshold: 1-9,000 seconds.

Certifications and compliance

Certifications obtained: GOST.

Compliant with standards: IEC/EN 61010-1, IEC/EN 61000-6-2, IEC/EN 61000-6-3.

For dimensions refer to page 16-31.

⊕ Independent adjustable delays.

Modular LED instruments three phase non expandable



DMK 70



DMK 70 R1



DMK 71



DMK 71 R1



DMK 75



DMK 75 R1

Order code	Displayed measurements	Output relay	Qty per pkg	Wt [kg]
	n°	n°	n°	[kg]
Voltmeter.				
DMK 70	3 phase voltage values	–	1	0.233
DMK 70 R1 ②	3 phase to phase voltage values 3 max phase voltage values 3 max phase to phase voltage values 3 min phase voltage values 3 min phase to phase voltage values	1	1	0.264
Ammeter.				
DMK 71	3 phase current values	–	1	0.241
DMK 71 R1 ②	3 max phase current values 3 min phase current values	1	1	0.272
Combined voltmeter, ammeter and wattmeter.				
DMK 75	3 phase voltage values	–	1	0.271
DMK 75 R1 ① ②	3 phase to phase voltage values 3 phase current values 4 active power values, phase and total 3 maximum phase voltage values 3 maximum phase to phase voltage values 3 maximum phase current values 4 max active power, phase and total 3 minimum phase voltage values 3 minimum phase to phase voltage values 3 minimum phase current values 4 min active power, phase and total	1	1	0.280

① Connection also to single phase.

② Relay output with control and protection functions.

General characteristics

The DMK 7... instruments are available with modular housing, 3-module size.

Measurements are True RMS values and provide for reliable operation even in presence of harmonics.

Operational characteristics

- Auxiliary supply voltage: 220-240VAC standard; 24VAC, 110-127VAC or 380-415VAC type on request
- Operating frequency: 50-60Hz
- True RMS measurements
- HIGH and LOW measurement storage
- 1 output relay with 1 changeover contact for DMK...R1 version only
- Terminals: 4mm²
- Modular DIN 43880 housing, 3-module
- Degree of protection: IP40 on front; IP20 on terminals.

DMK 70 - DMK 70 R1

- Voltage measurement range: 15-660VAC
- Operating frequency range: 45-65Hz
- Programmable VT ratio: 1.00-500.00
- Accuracy: ±0.25% f.s. ±1 digit

DMK 71 - DMK 71 R1

- Current measurement range: 0.05-5.75A
- Operating frequency range: 45-65Hz
- Programmable CT ratio: 5-10,000
- Accuracy: ±0.5% f.s. ±1 digit

DMK 75 - DMK 75 R1

- Voltage measurement range: 35-660VAC
- Current measurement range: 0.05-5.75A
- Frequency measure range: 45-65Hz
- Programmable VT ratio: 1.00-500.00
- Programmable CT ratio: 5-10,000
- Accuracy: Voltage ±0.25% f.s. ±1 digit
Current ±0.5% f.s. ±1 digit

Control and protection functions

DMK 70 R1

- Phase loss or failure: OFF/5-85%
- Maximum voltage: OFF/102-120%
- Minimum voltage: OFF/70-98%
- Asymmetry: OFF/2-20%
- Phase sequence: OFF/L1-L2-L3/L3-L2-L1
- Maximum frequency: OFF/101-110%
- Minimum frequency: OFF/90-99%
- Time delay for max-min voltage, phase loss, asymmetry and min-max frequency Ⓢ: 0.0-900.0 seconds.

DMK 71 R1

- Current loss: OFF/2-100%
- Maximum current: OFF/102-200%
- Maximum current instantaneous tripping: OFF/110-600%
- Minimum current: OFF/5-98%
- Asymmetry: OFF/2-20%
- Time delay for max-min current or current loss and asymmetry Ⓢ: 0.0-900.0 seconds.

DMK 75 R1

Voltage

- Phase loss or failure: OFF/5-85%
- Maximum voltage: OFF/102-120%
- Minimum voltage: OFF/70-98%
- Asymmetry: OFF/2-20%
- Phase sequence: OFF/L1-L2-L3/L3-L2-L1

Current

- Current loss: OFF/2-100%
- Maximum current: OFF/102-200%
- Maximum current instantaneous tripping: OFF/110-600%
- Minimum current: OFF/5-98%
- Asymmetry: OFF/2-20%

Power

- Rated power: 1-10,000
- Maximum power: OFF/101-200%
- Maximum power instantaneous tripping: OFF/110-600%
- Minimum power: OFF/10-99%

Frequency

- Maximum frequency: OFF/101-110%
- Minimum frequency: OFF/90-99%
- Time delay for max-min voltage, max-min current or current loss, phase loss, asymmetry and min-max power Ⓢ: 0.0-900.0 seconds.

Certifications and compliance

Certifications obtained: GOST.

Compliant with standards: IEC/EN 61010-1, IEC/EN 61000-6-2, IEC/EN 61000-6-3.

For dimensions refer to page 16-31.

Ⓢ Independent adjustable delays.

Expansion modules for flush-mount products



EXP10...

new

new

Order code	Description	Qty per pkg	Wt
		n°	[kg]
Inputs and outputs.			
EXP10 00	4 digital inputs, opto-isolated	1	0.060
EXP10 01	4 static outputs, opto-isolated	1	0.054
EXP10 02	2 digital inputs and 2 static outputs, opto-isolated	1	0.058
EXP10 03	2 relay outputs, rated 5A 250VAC	1	0.050
EXP10 04	2 analog inputs, opto-isolated 0/4...20mA, PT100, 0-10V or 0...±5V	1	0.056
EXP10 05	2 analog outputs, opto-isolated 0/4...20mA, 0-10V or 0...±5V	1	0.064
EXP10 06	2 relay outputs to increase number of steps	1	0.064
EXP10 07	3 relay outputs to increase number of steps	1	0.085
EXP10 08	2 opto-isolated digital inputs and 2 relay outputs rated 5A 250VAC	1	0.058
EXP10 40	2 digital/resistive inputs, 2 static outputs	1	0.058
EXP10 41	2 thermocouple inputs, 2 static outputs	1	0.058
Communication ports.			
EXP10 10	Opto-isolated USB interface	1	0.060
EXP10 11	Opto-isolated RS232 interface	1	0.040
EXP10 12	Opto-isolated RS485 interface	1	0.050
EXP10 13	Opto-isolated Ethernet interface with Web server function	1	0.060
EXP10 14	Opto-isolated Profibus-DP interface	1	0.080
Various functionality.			
EXP10 16	Capacitor bank protection	1	0.080
EXP10 30	Data storage, clock-calendar	1	0.050
EXP10 31	Data storage, clock-calendar with Energy Quality (EN 50160)	1	0.060

General characteristics

EXP series expansion modules can increase the functionality of the LOVATO Electric products, such as:

- Digital inputs
- Relay outputs
- Static outputs
- Analog inputs
- Inputs for PT100 temperature sensor
- Thermocouple inputs "J" or "K" types
- Analog outputs
- Communication interface
- Data storage.
- Powered directly by the base product
- Automatic identification by the base product
- Rear base product mounting with no need of tools.

Certifications and compliance

Certifications obtained: UL Listed, for USA and Canada (cULus File E93601), as Listed Accessory under Auxiliary Devices; EXP10 18 excluded.

Compliant with standards:

- For EXP10 04 and EXP10 10: IEC/EN 61010-1, IEC/EN 61000-6-2, IEC/EN 61000-6-4, UL508, CSA C22.2 n° 14
- For all other types: IEC/EN 61010-1, IEC/EN 61000-6-2, IEC/EN 61000-6-3, UL508 (pending for EXP10 40 and EXP10 41), CSA C22.2 n° 14 (pending for EXP10 40 and EXP10 41).

For overall dimensions, wiring diagrams and technical characteristics, consult the technical instructions in Downloads of the local or global websites; see details on inside front cover.

Expansion module fixing

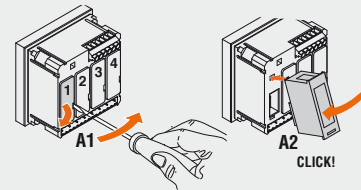

EXP series compatibility with LOVATO Electric products

TYPE	INTERFACE PROTECTION SYSTEM UNITS	DIGITAL MULTIMETERS			DIGITAL POWER ANALYZERS	POWER FACTOR CONTROLLERS	AUTOMATIC TRANSFER SWITCH CONTROLLERS		ENGINE AND GENERATOR CONTROLLERS				
	PMVF20/30	DGM 600/610	DGM 700	DGM 800	DGM 900/900T	DCRL 3/5/8	DCRG 8	ATL 610	ATL 800/900	RGK 4...SA	RGK 610...	RGK 800...	RGK 900...
EXP10 00		●	●	●	●		●	●	●			●	●
EXP10 01		●	●	●	●		●	●	●			●	●
EXP10 02		●	●	●	●		●	●	●			●	●
EXP10 03	●	●	●	●	●	●	●	●	●			●	●
EXP10 04				●	●		●	●	●			●	●
EXP10 05				●	●		●	●	●			●	●
EXP10 06						●	●	●	●				
EXP10 07						●	●	●	●				
EXP10 08		●	●	●	●		●	●	●			●	●
EXP10 10	●	●	●	●	●	●	●	●	●		●	●	●
EXP10 11	●	●	●	●	●	●	●	●	●		●	●	●
EXP10 12	●	●	●	●	●	●	●	●	●		●	●	●
EXP10 13	●	●	●	●	●	● (DCRL 8)	●	●	●		●	●	●
EXP10 14				●	●		●	●	●			●	●
EXP10 16							●						
EXP10 30				●	●		●						
EXP10 31					●								
EXP10 40										●		●	●
EXP10 41												●	●
Max n° of modules addable	2	1	4	4	4	1 (DCRL 3/5) 2 (DCRL 8)	4	2	3	1		3	4

Expansion modules for modular products



EXM10 00



EXM10 10

Order code	Description	Qty per pkg	Wt
		n°	[kg]
Inputs and outputs.			
EXM10 00	2 digital inputs and 2 static outputs, opto-isolated	1	0.137
EXM10 01	2 digital inputs, opto-isolated and 2 relay outputs, rated 5A 250VAC	1	0.147
EXM10 02	4 opto-isolated digital inputs and 2 relay outputs rated 5A 250VAC	1	0.155
Communication ports.			
EXM10 10	Opto-isolated USB interface	1	0.140
EXM10 11	Opto-isolated RS232 interface	1	0.125
EXM10 12	Opto-isolated RS485 interface	1	0.140
EXM10 13	Opto-isolated Ethernet interface with Web server function	1	0.140
EXM10 20	Opto-isolated RS485 interface and 2 relay outputs, rated 5A 250VAC	1	0.140
EXM10 30	Data storage, RTC with backup reserve energy for data logging	1	0.140

General characteristics

EXM series expansion modules can increase functionality of LOVATO Electric products, such as:

- Digital inputs
 - Relay outputs
 - Static outputs
 - Communication interface
 - Data storage.
- Connection to base product by IR (infrared beam) port
 – Automatic identification by the base product
 – Side base product mounting.

Certifications and compliance

Certifications obtained: EAC; UL Listed, for USA and Canada (cULus File E93601), as Listed Accessory under Auxiliary Devices; EXM10 18 excluded.

Compliant with standards:

- For EXM10 10: IEC/EN 61010-1, IEC/EN 61000-6-2, IEC/EN 61000-6-4, UL 508, CSA C22.2 n° 14
- For all other types: IEC/EN 61010-1, IEC/EN 61000-6-2, IEC/EN 61000-6-3, UL508, CSA C22.2 n° 14.

For overall dimensions, wiring diagrams and technical characteristics, consult technical instructions online in Downloads of the local or global website; see details on inside front cover.

Expansion module fixing



CLICK!

EXM series compatibility with LOVATO Electric products

	INTERFACE PRO. SYSTEM UNITS	ENERGY METERS		DATA CONCENTRATORS		DIGITAL MULTIMETER
	PMVF51	DMED 130	DME D310 T2	DME CD	DMED CDPV1	DMG 300
EXM10 00			●	●	●	●
EXM10 01	●	●	●	●	●	●
EXM10 02			●	●	●	●
EXM10 10	●		●	●	●	●
EXM10 11	●		●	●	●	●
EXM10 12	●		●	●	●	●
EXM10 13	●		●	●	●	●
EXM10 20			●	●	●	●
EXM10 30			●	●	●	●
Max n° of modules addable	2	1	3	3	3	3

Communication devices



CX 01



CX 02

Order code	Description	Qty per pkg	Wt
		n°	[kg]
CX 01	USB/optical dongle with PC ↔ LOVATO Electric product connecting cable, for programming, data download, diagnostics and firmware upgrade	1	0.090
CX 02	Wi-Fi dongle for PC ↔ LOVATO Electric product programming, data download, diagnostics and cloning	1	0.090

General characteristics

Communication devices for connection of LOVATO Electric products to personal computers, smartphones and tablets.

CX 01

The USB/optical dongle, complete with cable, allows the connection of products compatible with PCs without having to disconnect the power supply from the electric panel.

The PC identifies the connection as a standard USB.

CX 02

By Wi-Fi connection, compatible LOVATO Electric products can be viewed on PCs, smartphones and tablets with no need for cabling.

For dimensions, wiring schemes and technical characteristics, refer to technical instructions in the Downloads section at: www.LovatoElectric.com

Protection covers



31 PA96x96

Order code	Description	Qty per pkg	Wt
		n°	[kg]
PA 96X48	Front protection cover, IEC IP65 for DMK 0/1...	1	0.048
31 PA 96X96	Front protection cover, IEC IP54 for DMK 2...	1	0.077

General characteristics

When a higher front IP protection degree is needed, the covers can be installed on the corresponding devices and also provide a sealing feature.

Accessories



EXP80 00

Order code	Description	Qty per pkg	Wt
		n°	[kg]
EXP80 00	Plastic insert for customising label fixing for DMG 600/610	10	0.005
EXM80 04	Set of sealable terminal covers for DMG 100/101/110/200/210/300	1	0.020

Converter drive



EXC CON 01



Order code	Description	Qty per pkg.	Wt
		n°	[kg]
EXC CON 01	RS485/Ethernet 12...48VDC converter, including DIN rail fixing kit	1	0.400
4 PX1	RS232/RS485 galvanically isolated converter supply 220...240VAC (or 110...120VAC). Repeater for bus extension RS485	1	0.600



4 PX1

General characteristics

EXC CON 01 CONVERTER
The EXC CON 01 converter allows "slave" devices connected on an RS485 network to interface with a "master" featuring Ethernet port:

- kit comprising converter and DIN rail mounting accessory;
- programming via web interface;
- power supply not included.

4 PX1 CONVERTER DRIVE (RS232-RS485)

It can interface "slave" devices connected in an RS485 bus with a "master" equipped with RS232 interface port. When configured appropriately, it can also be used as RS485 repeater whenever the devices connected to the bus are many or the maximum distance among the bus devices is longer than the allowed.

EXC M3G 01 GATEWAY

The EXC M3G 01 gateway allows "slave" devices connected on an RS485 network to interface with a "master" via 3G network:

- TCP server connection via 3G or 2G network;
- transparent operating mode: the data is transferred from 3G side to serial side and vice versa without protocol conversion;
- parameters that can be set: TCP server remote port and IP, network operator APN (with username and password), SIM card PIN (with enablement), connection timeout, serial parameters (baud rate from 1200bps to 115200bps, stop bit, number of characters, parity);
- RJ45 port for parameter programming and diagnosis with a simple software application.
- Compatible with major worldwide mobile phone networks, thanks to the use of 850/900/1800/1900/2100MHz frequencies. Protection rating IP67. Fixing hole Ø10mm. Cable length 2.5m.

Gateway



EXC M3G 01



Order code	Description	Qty per pkg.	Wt
		n°	[kg]
EXC M3G 01	RS485/3G modem, 9.5...27VAC/9.5...35VDC, including antenna and programming cable, length 2.5m	1	0.340

Connecting cables



51 C4

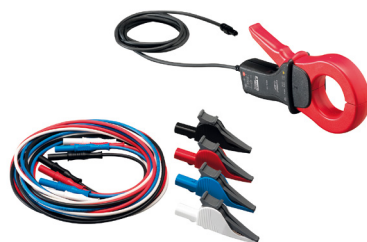

DMG M3 KIT...

Order code	Description	Qty per pkg.	Wt
		n°	[kg]
51 C2	For PC-multimeter RS232 port, 1.8m long	1	0.090
51 C4	For PC-4 PX1 converter drive, 1.8m long	1	0.147
51 C5	For analog modem-multimeter RS232 port, 1.8m long	1	0.111
51 C9	For 4PX 1 converter drive-analog modem, 1.8m long	1	0.137

Current clamp kits for DMG M3... portable devices

DMG M3 KIT01	Composed by 3 current clamps 1000/1 and 4 alligator clip cables for voltage measurements	1	6.900
DMG M3 KIT02	Composed by 1 current clamps 1000/1 and 1 alligator clip cable for voltage measurements. For DMGM3900, if measuring inputs for neutral-earth/ground and neutral current are used too	1	0.860

CONNECTING CABLES 51 C...

To connect energy meters and/or multimeters with:

- Personal computers
- Modems
- Bus converters.

Electrical safety for DMG M3 KIT...

(IEC/EN 61010-1 and IEC/EN 611-2-032)

CURRENT CLAMPS

- 600V category III
- 300V category IV.

VOLTAGE MEASURING CABLES

- 1000V category III.

Reference standards

Compliant with standards: IEC/EN 61010-1, IEC/EN 61000-6-2, IEC/EN 61000-6-3.

For dimensions, wiring schemes and technical characteristics, refer to technical instructions in Downloads at www.LovatoElectric.com.

Solid-core



DM0T...



DM2T...

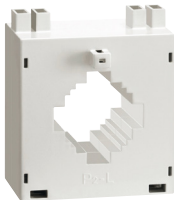

DM3T...



DM35T...

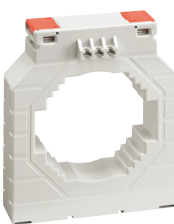

DM4T...

Order code	Primary current I _{pn}	Burden		Qty per pkg.	Weight [kg]
		cl. 0,5 [VA]	cl. 1 [VA]		
For Ø22mm/0.87" cable.					
DM0T 0050	50	—	1.25	1	0.200
DM0T 0060	60	—	1.5	1	0.200
DM0T 0080	80	—	1.5	1	0.200
DM0T 0100	100	—	1.5	1	0.200
DM0T 0150	150	—	2	1	0.200

For Ø23mm/0.90" cable.
For 30x10mm/1.18x0.39", 25x12.5mm/0.98x0.49", 20x15mm/0.79x0.59" busbars.

DM2T 0100	100	—	1	1	0.130
DM2T 0150	150	—	1.5	1	0.130
DM2T 0200	200	—	2	1	0.130
DM2T 0250	250	—	2.5	1	0.130
DM2T 0300	300	1.5	3	1	0.130
DM2T 0400	400	2	3	1	0.130

For Ø30mm/1.18" cable.
For 40x10mm/1.57x0.39", 30x20mm/1.18x0.79", 25x25mm/0.98x0.98" busbars.

DM3T 0200	200	—	5	1	0.260
DM3T 0250	250	—	5	1	0.260
DM3T 0300	300	2.5	5	1	0.260
DM3T 0400	400	2.5	5	1	0.260
DM3T 0500	500	2.5	5	1	0.260
DM3T 0600	600	5	10	1	0.260
DM3T 0800	800	5	10	1	0.260

For Ø66mm/2.60" cable.
For 80x12.5mm/3.15"x0.49", 60x30mm/2.36x1.18", 50x50mm/1.97x1.97" busbars.

DM35T 0800	800	10	15	1	0.460
DM35T 1000	1000	15	20	1	0.460
DM35T 1250	1250	15	20	1	0.460

For Ø86mm/3.38" cable.
For 100x30mm/3.94x1.18", 80x50mm/3.15x1.97", 70x60mm/2.75x2.36" busbars.

DM4T 1000	1000	10	20	1	0.700
DM4T 1250	1250	15	30	1	0.760
DM4T 1500	1500	20	30	1	0.760
DM4T 1600	1600	20	30	1	0.800
DM4T 2000	2000	30	45	1	0.840
DM4T 2500	2500	35	45	1	0.900
DM4T 3000	3000	45	45	1	0.900
DM4T 3500	3500	50	50	1	0.900
DM4T 4000	4000	50	50	1	0.900



General characteristics

The instrument transformers (CTs) in the DM series are installed in an electrical system to reduce the line current to a secondary value of 5A compatible with the ammeter inputs of the digital multimeters or protection relays. DM... are instrument transformers in class 1/0.5 without a primary winding and are normally used for high primary current values starting from 50A.

The number of loops of the primary cable does not modify the accuracy but converts the primary current value proportional to secondary current.

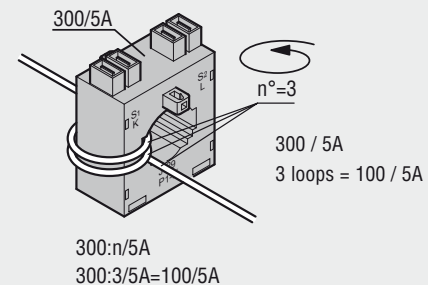
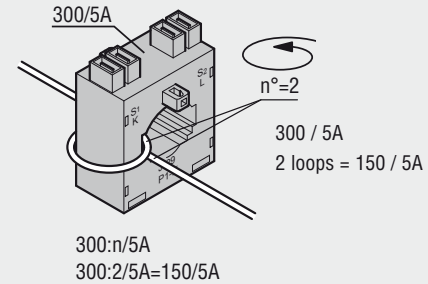
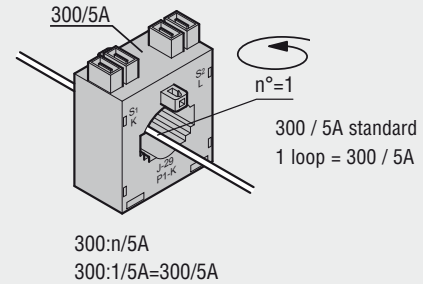

Operational characteristics

- Operating frequency: 50-60Hz
- Secondary output current: 5A
- Overload withstand: 120% I_{pn}
- IEC rated insulation voltage U_i: 720V
- IEC rated short-time thermal current I_{th}: 40-60 I_{pn} for 1 second
- IEC rated dynamic current I_{dyn}: 2.5 I_{th} for 1 second
- Insulation (dry type): Class E
- Terminals:
 - Faston for DM2T and DM3T types
 - Screw for DM0T, DM4T and DM5T types
- Sealable terminal covers for DM0T, DM4T and DM35T types
- Fixing on 35mm DIN rail (IEC/EN 60715) or by screws (fixing elements standard supplied with the product)
- IEC degree of protection: IP30
- Ambient conditions
 - Operating temperature: -25 ... +50°C
 - Storage temperature: -40 ... +80°C.
 - Relative humidity, non condensing: 90%.

Reference standards

Compliant with standards: IEC/EN 61869-2, IEC/EN 61869-1.

Solid-core accuracy

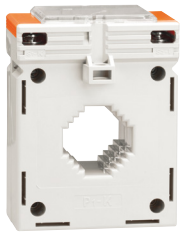

DM1TP...



DM3TP...

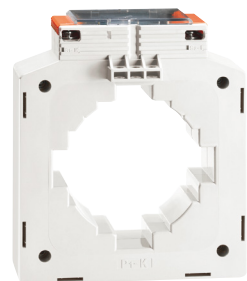

DM5TP...

new

new

new

Order code	Primary current I _{pn}	Burden		Qty per pkg.	Weight [kg]
		cl. 0,5s [VA]	cl. 0,5 [VA]		
	/5 [A]			n°	

For Ø28mm/1.10" cable.
For 30x10mm/1.18x0.39", 25x12.5mm/0.98x0.49",
20x20mm/0.79x0.79" busbar.

DM1TP 0060	60	1.5	1.5	1	0.560
DM1TP 0080	80	2.5	2.5	1	0.580
DM1TP 0100	100	2.5	3.75	1	0.480
DM1TP 0150	150	2.5	3.75	1	0.480
DM1TP 0200	200	2.5	3.75	1	0.480
DM1TP 0250	250	2.5	5	1	0.480
DM1TP 0300	300	2.5	5	1	0.480
DM1TP 0400	400	5	5	1	0.480
DM1TP 0500	500	5	5	1	0.480

For Ø52mm/2.04" cable.
For 60x20mm/2.36x0.79", 50x25mm/1.97x0.98" busbar.

DM3TP 0500	500	3.75	5	1	0.700
DM3TP 0600	600	5	10	1	0.700
DM3TP 0800	800	5	10	1	0.700
DM3TP 1000	1000	5	10	1	0.700

For Ø66mm/2.60" cable.
For 100x20mm/3.94x0.79", 80x45mm/3.15x1.77" busbar.

DM5TP 1000	1000	5	10	1	0.900
DM5TP 1250	1250	7.5	10	1	0.900
DM5TP 1600	1600	7.5	10	1	0.900
DM5TP 2000	2000	10	15	1	0.900
DM5TP 2500	2500	10	15	1	0.900
DM5TP 3000	3000	10	15	1	0.900

For Ø33mm cable. For 40x10mm, 30x20mm, 25x25mm busbar.

General characteristics

The DM...TP type accuracy current transformers (CTs) are installed in an electrical system to reduce the line current to a secondary value of 5A compatible with the ammeter inputs of the digital multimeters or protection relays. DM...TP are accuracy current transformers in class 0.5s without a primary winding and are normally used for high primary current values starting from 60A. The number of loops of the primary cable does not modify the accuracy but converts the primary current value proportional to secondary current.

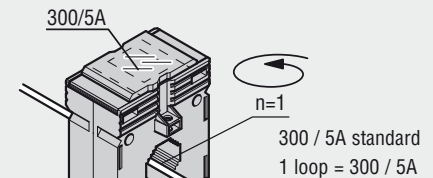

300:n/5A
300:1/5A=300/5A

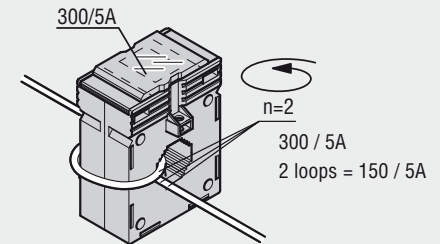

300:n/5A
300:3/5A=100/5A

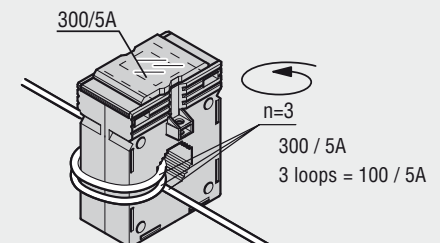

300:n/5A
300:3/5A=100/5A

Operational characteristics

- Operating frequency: 50-60Hz
- Secondary output current: 5A
- Overload withstand: 120% I_{pn}
- IEC rated insulation voltage U_i: 720V
- IEC rated short-time thermal current I_{th}: 40-60 I_{pn} for 1 second
- IEC rated dynamic current I_{dyn}: 2.5 I_{th} for 1 second
- Insulation (dry type): Class E
- Screw terminals
- Sealable terminal covers
- Fixing on 35mm DIN rail (IEC/EN 60715) or by screws (fixing elements standard supplied with the product)
- IEC degree of protection: IP30
- Ambient conditions
 - Operating temperature: -25 ... +50°C
 - Storage temperature: -40 ... +80°C.
 - Relative humidity, non condensing: 90%.

Reference standards

Compliant with standards: IEC/EN 61869-2, IEC/EN 61869-1.

Compact prewired split-core



DM1TMA...

new



DM2TMA...

new

Order code	Primary current I _{pn}	Burden		Qty per pkg.	Weight [kg]
		cl. 0,5 [VA]	cl. 1 [VA]		
24x24mm/0.94x0.94" hole. Cable supplied as standard, length 1m.					
DM1TMA 0100	100	—	1.2	1	0.200
DM1TMA 0150	150	—	1.2	1	0.200
DM1TMA 0200	200	—	1.2	1	0.200
DM1TMA 0250	250	—	1.2	1	0.200
36x38mm/1.42x1.50" hole. Cable supplied as standard, length 1m.					
DM2TMA 0250	250	—	1.5	1	0.380
DM2TMA 0300	300	—	1.5	1	0.380
DM2TMA 0400	400	—	1.5	1	0.380
DM2TMA 0500	500	—	1.5	1	0.380

General characteristics

The DM...TMA type instrument transformers (CTs) are installed in an electrical system to reduce the line current to a secondary value of 5A compatible with the ammeter inputs of the digital multimeters or protection relays. DM...TMA are instrument transformers in class 1 without a primary winding and are normally used for high primary current values starting from 100A.

Operational characteristics

- Operating frequency: 50-60Hz
- Secondary output current: 5A
- Overload withstand: 120% I_{pn}
- IEC rated insulation voltage U_i: 720V
- IEC rated short-time thermal current I_{th}: 40-60 I_{pn} for 1 second
- IEC rated dynamic current I_{dyn}: 2.5 I_{th} for 1 second
- Cable supplied as standard, length 1m.
- Insulation (dry type): Class E
- Ambient conditions:
 - Operating temperature: -25...+50°C
 - Storage temperature: -40...+80°C
 - Relative humidity, non condensing: 90%.

Reference standards

Compliant with standards: IEC/EN 61869-2, IEC/EN 61869-1.

Split-core



DM1TA...



DM2TA...



DM3TA...



DM4TA...

Order code	Primary current I _{pn}	Burden		Qty per pkg.	Weight [kg]
		cl. 0,5 [VA]	cl. 1 [VA]		
50x80mm/1.97x3.15" hole.					
DM1TA 0250	250	1	2	1	0.900
DM1TA 0300	300	1.5	3	1	0.900
DM1TA 0400	400	1.5	3	1	0.900
DM1TA 0500	500	2.5	5	1	0.900
DM1TA 0600	600	2.5	5	1	0.900
DM1TA 0800	800	3	7.5	1	0.900
DM1TA 1000	1000	5	10	1	0.900
80x80mm/3.15x3.15" hole.					
DM2TA 0250	250	1	2	1	1.050
DM2TA 0300	300	1.5	3	1	1.050
DM2TA 0400	400	1.5	3	1	1.050
DM2TA 0500	500	2.5	5	1	1.050
DM2TA 0600	600	2.5	5	1	1.050
DM2TA 0800	800	3	7.5	1	1.050
DM2TA 1000	1000	5	10	1	1.050
80x120mm/3.15x4.72" hole.					
DM3TA 0500	500	—	4	1	1.250
DM3TA 0600	600	—	5	1	1.250
DM3TA 0800	800	3	7.5	1	1.250
DM3TA 1000	1000	5	10	1	1.250
DM3TA 1250	1250	7.5	15	1	1.250
DM3TA 1500	1500	8	17	1	1.250
80x160mm/3.15x6.30" hole.					
DM4TA 2000	2000	15	20	1	3.160
DM4TA 2500	2500	15	20	1	3.340
DM4TA 3000	3000	20	25	1	3.500
DM4TA 4000	4000	20	25	1	3.760

General characteristics

The DM...TA type instrument transformers (CTs) are installed in an electrical system to reduce the line current to a secondary value of 5A compatible with the ammeter inputs of the digital multimeters or protection relays. DM...TA are instrument transformers in class 0.5/1 without a primary winding and are normally used for high primary current values starting from 250A.

Operational characteristics

- Operating frequency: 50-60Hz
- Secondary output current: 5A
- Overload withstand: 120% I_{pn}
- IEC rated insulation voltage U_i: 720V
- IEC rated short-time thermal current I_{th}: 40-60 I_{pn} for 1 second
- IEC rated dynamic current I_{dyn}: 2.5 I_{th} for 1 second
- Insulation (dry type): Class E
- Screw terminals
- Sealable terminal covers
- Screw fixing (fixing elements standard supplied with the product)
- IEC degree of protection: IP30
- Ambient conditions:
 - Operating temperature: -25 ... +50°C
 - Storage temperature: -40 ... +80°C.
 - Relative humidity, non condensing: 90%.

Reference standards

Compliant with standards: IEC/EN 61869-2, IEC/EN 61869-1.

Synergy

Synergy is supervision and energy management web-based software that provides for the monitoring and control of the electrical installation, in a simple and efficient way. It is valid software to sustain the activities indicated by the standard EN ISO 50001 "Energy management systems. Requirements with guidance for use". In addition to electrical quantities, it allows to check all environmental and process information (operating status, alarms, etc.), acquired from LOVATO Electric products, equipped with communication port, and thereby to carry out commands and parameterising. It is possible to create, without limitations, pages of browsable graphs data logging and trend graphs; it is also possible to manage alarms, exported files and e-mail and/or FTP server transmission functions for notification and reporting.

● FUNCTIONALITY

- Communication with all LOVATO Electric measurement and control devices, via serial ports, Ethernet or modem
- Database of instantaneous values
- Creation of custom graph pages
- Datalog files
- Energy consumption reports
- Graphic display of trends
- Automatic reports of consumption periods (e.g. time bands) in both analytical and graphic format
- Alarm management, both locally and via e-mail
- Energy quality analysis
- Field equipment parameterising
- Access level management.

● SIMPLE, GUIDED, INTUITIVE CONFIGURATION

Programming **Synergy** does not require any particular computer knowledge since specific configuring instruments have been developed to guide through the configuration of product networks, graphic pages, datalog reports and charts, in a simple and intuitive way.

● SERVER-MULTICLIENT SYSTEM

Synergy structure and applications are based on a MS SQL relational database management system.

Synergy is consulted through the most popular browsers, so it's available on various platforms and operating systems. These characteristics make **Synergy** a highly versatile system, simultaneously accessible to a large number of users/workstations via intranets, VPN or Internet.

● INTERFACE

Synergy permits the creation of an unlimited number of pages to monitor the system in real time. With great simplicity, it is possible to insert static images and dynamic objects of various types, to make pages with system overviews, synoptic and/or topographic representations of the electrical network with all detailed information. The buttons can be used to send commands to the systems (provided that there are appropriate field actuators) or navigate among the pages.

The dynamic objects available are:

- analogue instruments at 90° and 270°
- digital instrumentation
- digital instrumentation with vertical or horizontal bar graphs
- 10-digit hour counter
- simple label or with dynamic image
- normal or reduced multi-measurement panel
- specific power factor controller panel
- specific generating set controller panel
- chart of single measurements
- harmonics graph
- control and/or page navigation buttons

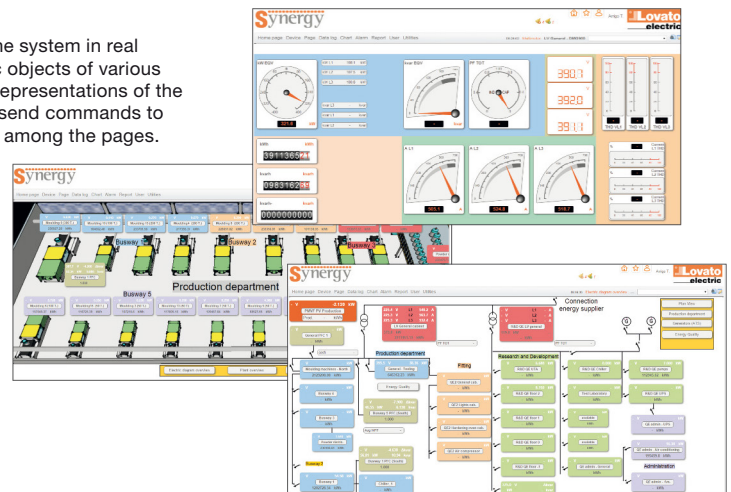

● ALARMS

Each value recorded in the archives (datalog) can be associated with one or more alarms, defining for each one: an upper and lower limit, a reference calendar (for enabling/disabling), any representation in trend graphs and the option of automatically sending an e-mail. If the limits are exceeded, **Synergy** records the anomaly and reports it in the software header. The home page always indicates the last 10 alarms, while the specific menu allows the display of detailed information, silencing of alarms and consultation of the datalog.

● HOME PAGE

The **Synergy** start page summarises the main diagnosis information, to permit immediate verification of the state of the system.

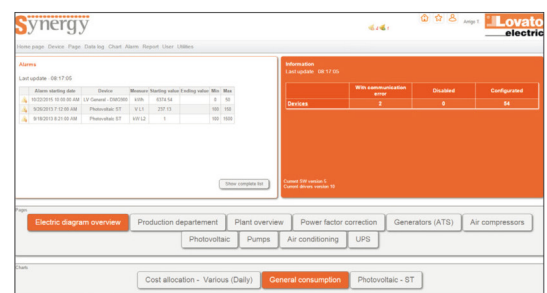

● FURTHER INFORMATION

For further information on the **Synergy** software, consult the site: em.LovatoElectric.com/Synergy

Software **Synergy**

Order code	Description	Qty per pack	Wt
		n°	[kg]
SYN1 SET	Supervision and energy management software (parameterising, measurement, monitoring, control, web server, e-mail and FTP file transfer) + enablement of monitoring on 1 LOVATO Electric devices	1	0.210
SYN 1 S005	Enable licence of supervision function for 5 additional devices	-	-
SYN 1 S020	Enable licence of supervision function for 20 additional devices	-	-
SYN 1 S050	Enable licence of supervision function for 50 additional devices	-	-
SYN 1 S100	Enable licence of supervision function for 100 additional devices	-	-

NOTE: For the number of licences, only devices equipped with communication port can be considered.

Synergy is remote control and supervision software for LOVATO Electric devices equipped with communication via serial ports, Ethernet or modem. The supported protocols are Modbus-RTU, Modbus-ASCII and Modbus-TCP.

Its structure and applications are based on MS SQL Express that uses a MS IIS Express web server to control the user interface.

The software is capable of:

- Managing multiple communication channels simultaneously
- Connecting the devices to the various channels
- Collecting data from all the devices and storing them in a database
- Displaying collected data in graphical pages and tables
- Generating graphs and alarms starting from the content of the data tables
- Allowing access to the devices and their data according to the rights of the different users.

Order Example

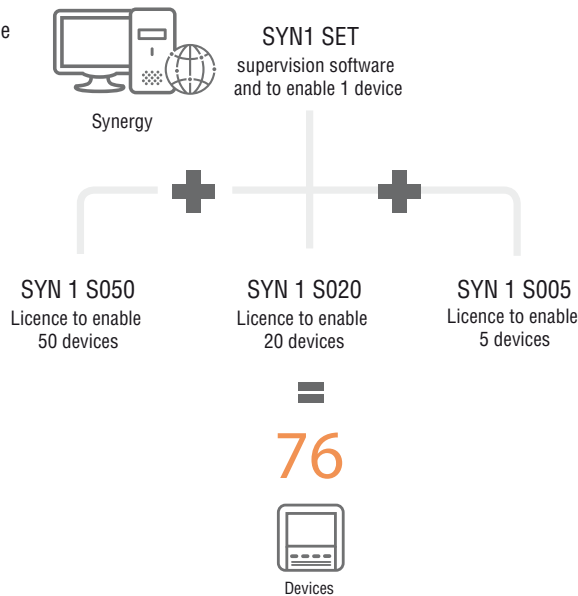



The **Synergy** cloud solution is specifically designed to make the **Synergy** software function described previously available and accessible via PC or tablet on the **cloud.LovatoElectric.com** Internet portal.

With **Synergy**, it's possible to check and view the electrical and energy data for the measurements and statuses recorded by the LOVATO Electric measurement and/or control devices without installing software and without a physical server. This saves on server purchasing, configuration and maintenance costs and eliminates commissioning times and costs.

The cloud portal is extremely simple and self-configuring and meets the most common measurements requirements of energy managers. To create it, various sampling scenarios were designed and can be assigned to the individual devices in accordance with the logic most appropriate to the needs of the user. For detail of the LOVATO Electric devices that can be monitored and the scenarios that can be assigned during registration, please consult the **cloud.LovatoElectric.com** site in the product guide section. Communication between the field instrumentation and cloud server is carried out through the typical rules of the Modbus protocol. A Master Modbus is activated on the Cloud which collects the data from the field devices (slave Modbus) configured as clients directed at the server: consequently, they don't require a public static IP address, just I/O access to the Internet.

SECURITY

The security of the data is guaranteed by HTTPS encryption with certificate between server and client PC, by daily backup of the data collected and by state-of-the-art firewall for server access.

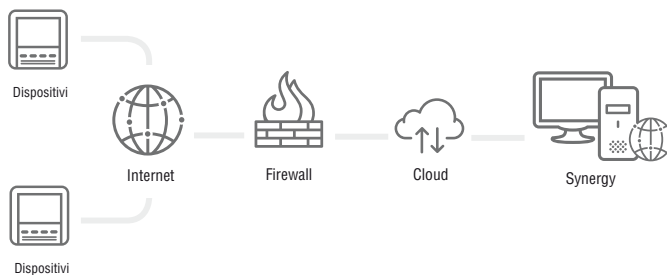

FEATURES

- Extremely intuitive interface: no particular technical background required
- Data access from all over the world thanks to the Internet and common browsers
- Specific design for client requirements (selection of measurement scenarios)
- Low data traffic thanks to the extreme economy of the protocol used (Modbus)
- Instantaneous data acquisition from various devices that can even be located in different sites
- Simple and clear reporting of all energy data
- No investment in software database or server
- Extremely secure data thanks to HTTPS and daily backup
- Automatic updates included
- Limited subscription cost.

Synergy Cloud Software

Order code	Description
Fixed annual licence: pages, datalogger, graphs predefined.	
SYN1 C005 F	For 5 devices monitored
SYN1 C010 F	For 10 devices monitored
SYN1 C020 F	For 20 devices monitored
Customisable annual licence: pages, datalogger, graphs can be customised	
SYN1 C020 C	For 20 devices monitored
SYN1 C050 C	For 50 devices monitored

Order codes

The services offered depend on the annual (365 days from activation date) subscription activated. There are two types of licence: FIXED and CUSTOMISABLE.

Fixed licence

For each instrument connected, there are monitoring scenarios in which the values monitored and consequent representations (device web page, online measurements, datalogger, graphs, report) are defined. The system is self-configuring and cannot be modified by the user. The maximum number of devices monitored is 20. This solution is most suited to those who find their requirements met among the various scenarios proposed. The skills required to manage the system are extremely limited.

Customisable licence

Offers the same services as the FIXED solution, with the difference that the client is free to modify the proposed measurement scenarios, web pages, data loggers and reports as they see fit. The client can also create sub-users and assign them with specific access. The maximum number of devices monitored is 50. This solution is most suited to those who need a flexible solution that can be customised in accordance with their requirements. The ability to manage the system can be acquired by downloading the tutorial from the video section on the site: **em.LovatoElectric.com**.

Maintaining the default configurations, whatever the scenarios selected, the energy data is kept online for at least a year and the measurement data (e.g. V, I, PF, kW) for at least two months. The automatic export function allows the transfer of the data collected via e-mail so that the datalog is preserved. To find out the composition of the various scenarios, please access the site: **cloud.LovatoElectric.com**.

Synergy cloud therefore meets both basic requirements with a preconfigured product with only the possibility of seeing and collecting the data and complex requirements where it is necessary to perform customisation, including complex customisation, in terms of data processing, graphic interfaces, creation of sub-users, etc.

Xpress

Xpress is parameter configuration and remote monitoring software shared by the entire latest generation of LOVATO Electric products with communication port. It can be installed in the Windows environment and connect individually (one node at a time) to the LOVATO Electric products connected to the network.

- Supports connection via CX01 (USB), CX02 (Wi-Fi), RS232, RS485, Ethernet and modem.
- Product configuration:
 - parameter setting
 - project file management for the family of controllers for RGK series generating sets
- Product firmware update (via CX01)
- Remote control:
 - monitoring of main measurements
 - sending commands to products
- Reading alarms and events memory.

Consult the www.LovatoElectric.com site for the list of products supported by Xpress.

Xpress can be ordered using code SYN1 XP00 or downloaded for free from: <http://www.lovatoelectric.co.uk/xpressdownload.aspx>

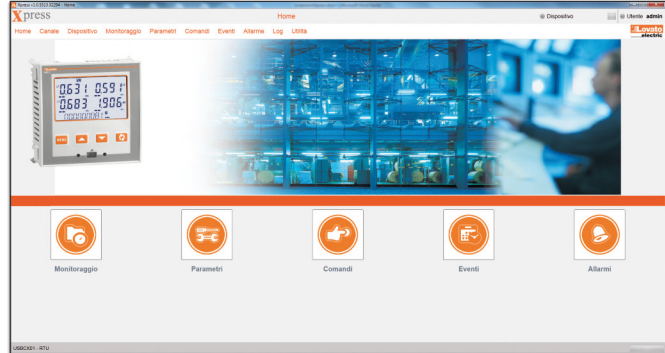

MONITORING

The measurements of the product connected are divided into context menus to make searching for the right value easy and shown on appropriate graphical gauges.

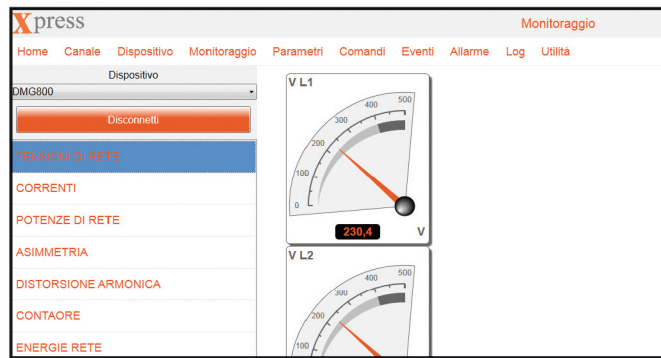

COMMANDS

A command can be sent to the product connected to energise outputs or reset energy consumption or operating time counters for maintenance.

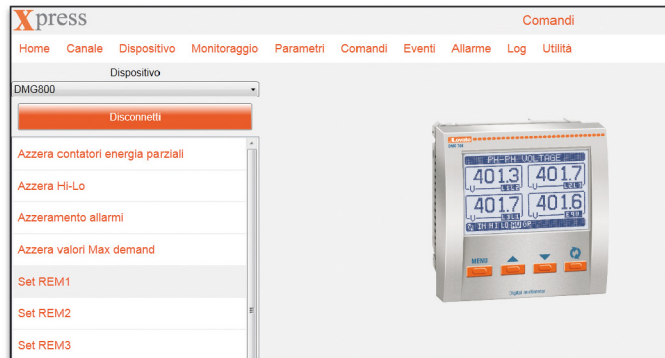

PARAMETERS

The options in the setup menu and parameters on the product connected are replicated in the software to allow the user to operate using the terms that they already know. Parameters that differ from the factory values are highlighted in a different colour.

The parameters can be saved to a file and recalled in subsequent installations, or defined even in the absence of a connection to the product, to permit preparation of a project to send subsequently.

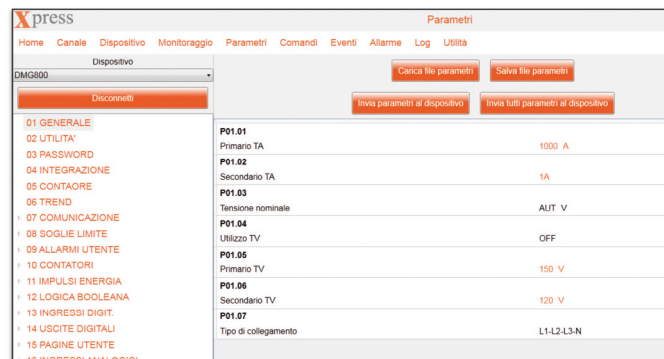

ALARMS

The alarms active on the product connected can be displayed in the software, for a single screen with the complete list of the faults detected.

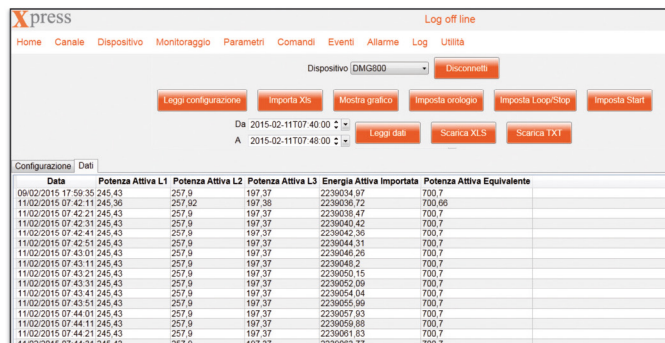

DATA-LOGGER MEMORY MANAGEMENT

Xpress can be used to configure and manage the EXP10 30 and EXM10 30 memory modules, in order to create tables indicating the history of the measurements selected by the user.

In particular, the software can be used to set:

- the measurements to be sampled
- the sampling time
- the event that triggers and ends sampling
- memory capacity management (FIFO or stop when memory is full).

The data acquired can be displayed in graphs and exported to text files or spreadsheets.

METERING INSTRUMENTS AND CURRENT TRANSFORMERS

Software and Applications



APP

Sami

Updating driver



Sending e-mail (events, parameters)

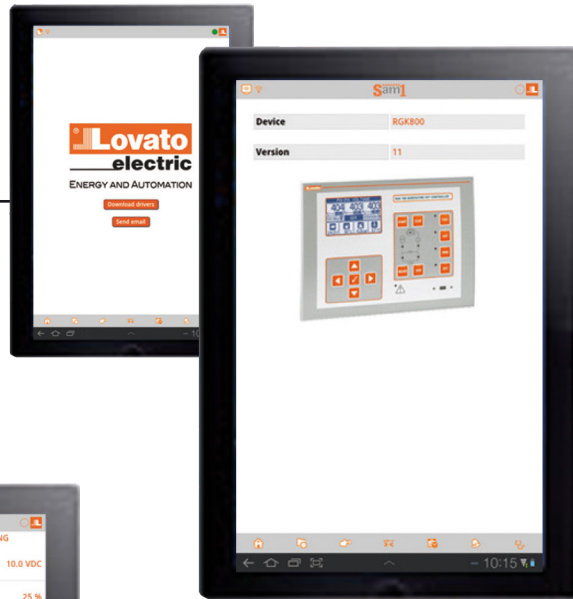

General characteristics

Configuration and maintenance operations, often done in intolerable or awkward ambience due to weather or noisy conditions or narrow places, are now easier to do for all LOVATO Electric devices with communication interface on front, compatible with CX02 dongle. Tablets and smartphones with Android or iOS operating system can connect to them using the new application called **Sami** (Setting And Maintenance 1). Therefore, it is no longer necessary to connect and switch on a PC using cables to change configurations, set up parameters etc. With this APP, a file previously saved can be uploaded; commands can be sent; measured quantities can be read from LOVATO Electric devices. The events can be viewed and saved in a text file and later copied and sent by email or to FTP servers. The **Sami** app can be downloaded from Google Play Store or Apple iTunes.



SETTING PARAMETERS

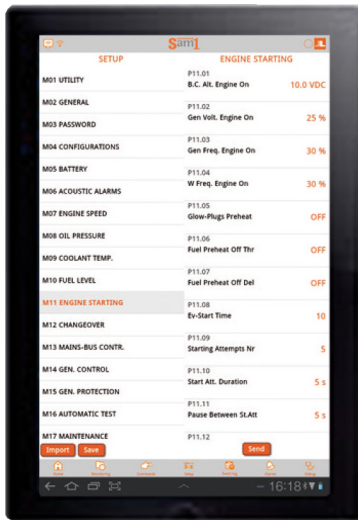

SENDING COMMANDS



VIEWING EVENT LOG



VIEWING ALARMS

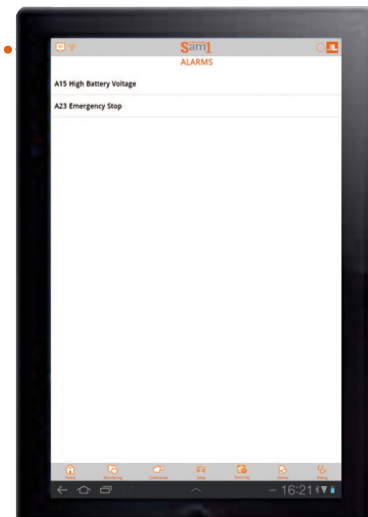

VIEWING MEASUREMENTS

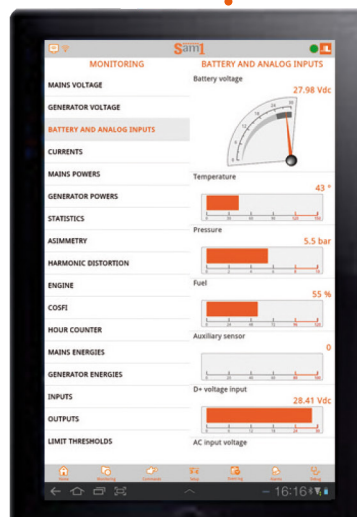

APP

NFC

Updating driver



Sending e-mail (parameters)

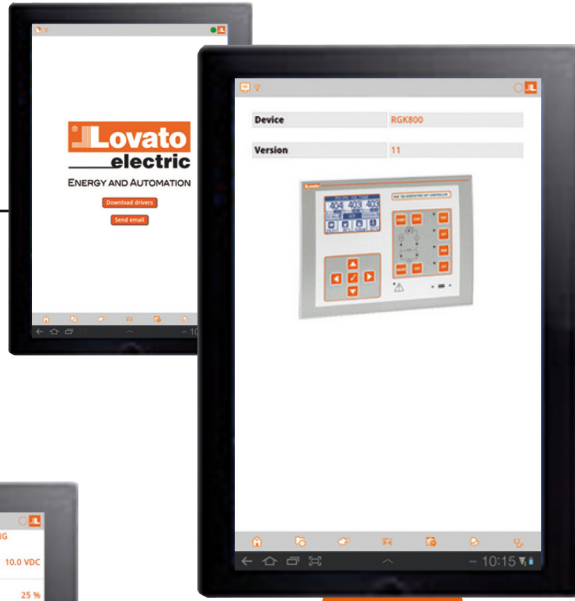

General characteristics

Some LOVATO Electric products can now have their parameters programmed via tablet and smartphone through NFC wireless technology. Bringing the display of a smartphone or tablet (with NFC connection enabled) close to a LOVATO Electric product, activates the **NFC** app and the device connected is recognised automatically. The parameters can be set without supplying the LOVATO Electric device.

The application allows you to:

- Set the parameters for the product connected
- Save the parameters in a file and send it via e-mail
- Load a parameter file saved previously.

The app can be downloaded from Google Play Store.



SETTING PARAMETERS

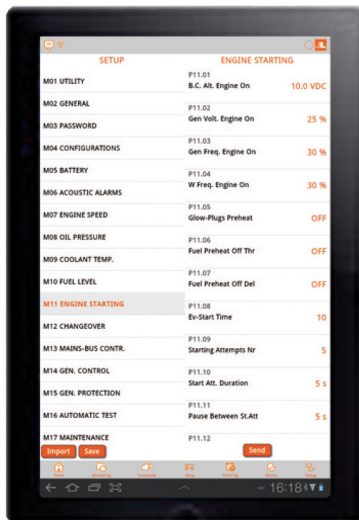

System Management

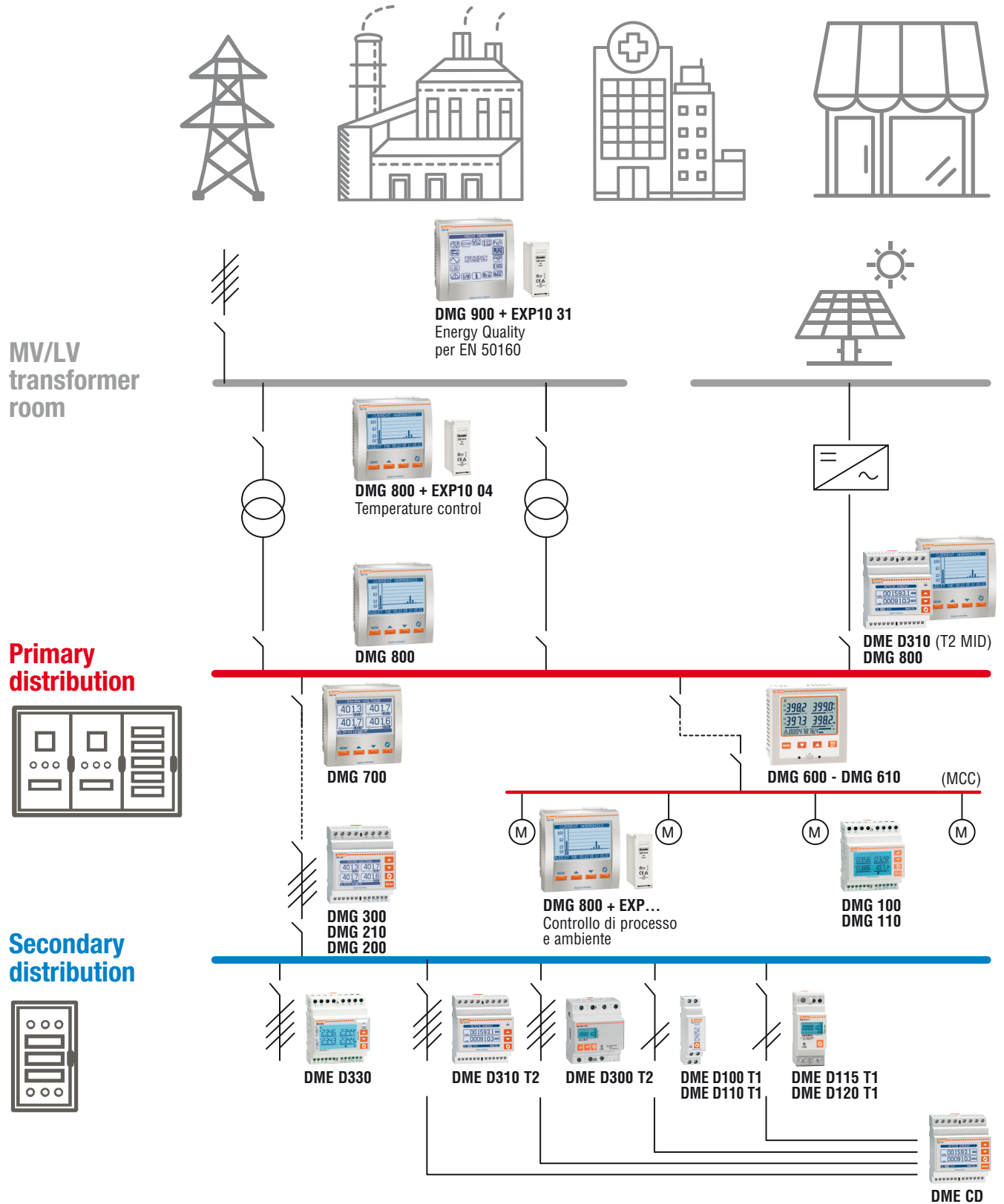

Lovato Electric Device Monitoring

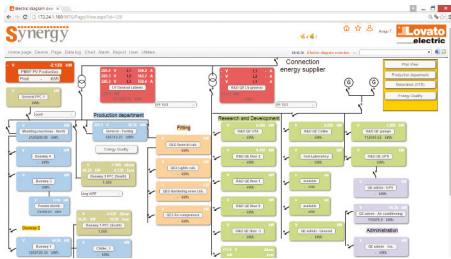
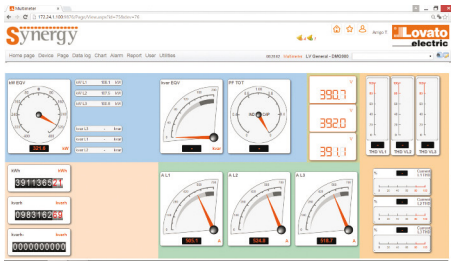
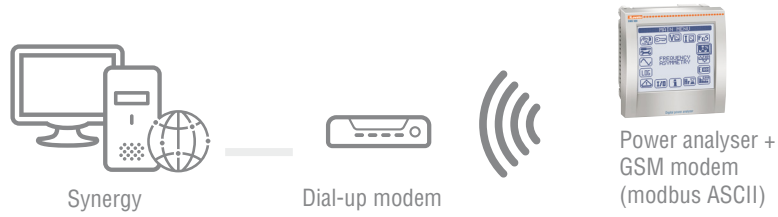

Synergy

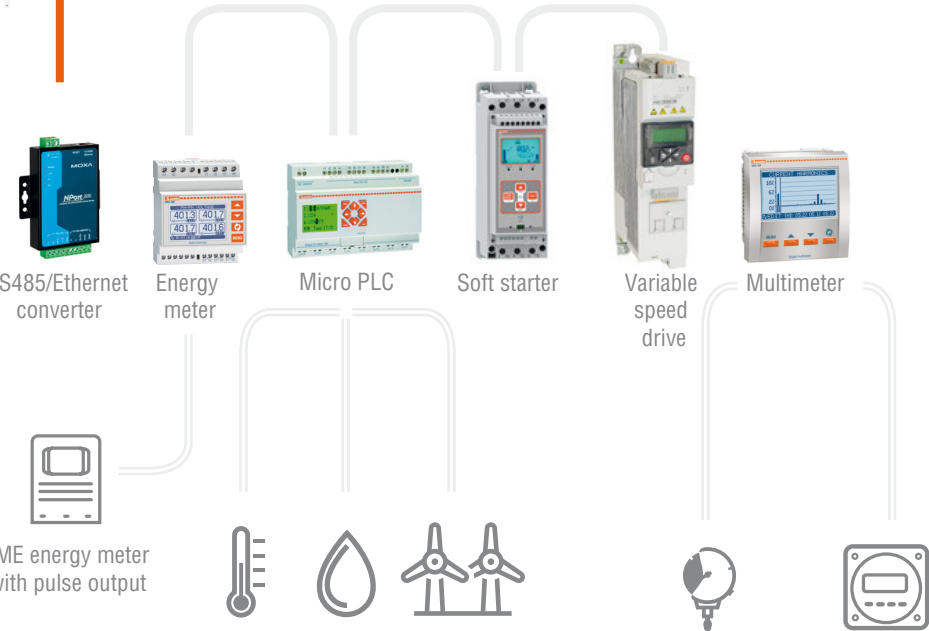
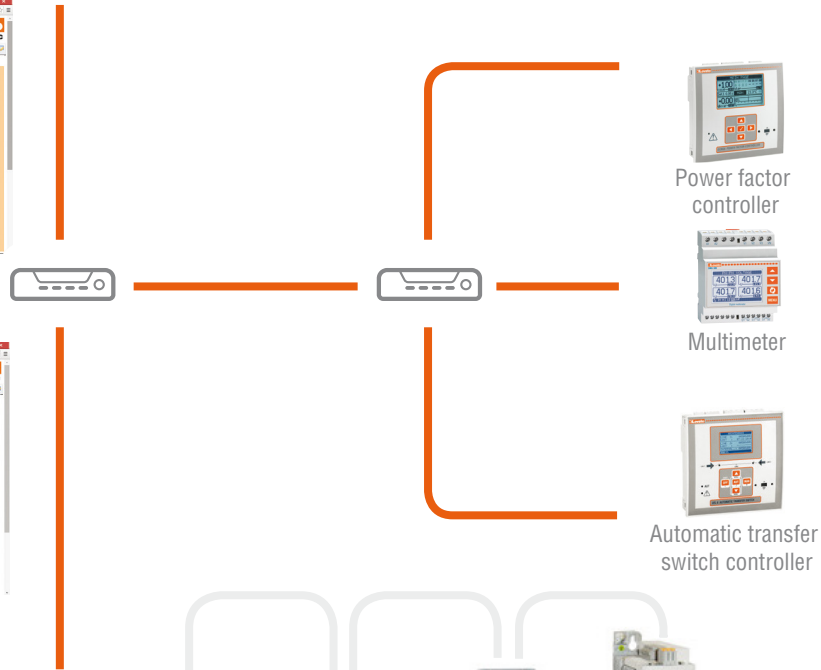

- Ethernet
- RS485
- Electrical signal

METERING INSTRUMENTS AND CURRENT TRANSFORMERS

Digital Metering Instruments



Photovoltaic Installation Management

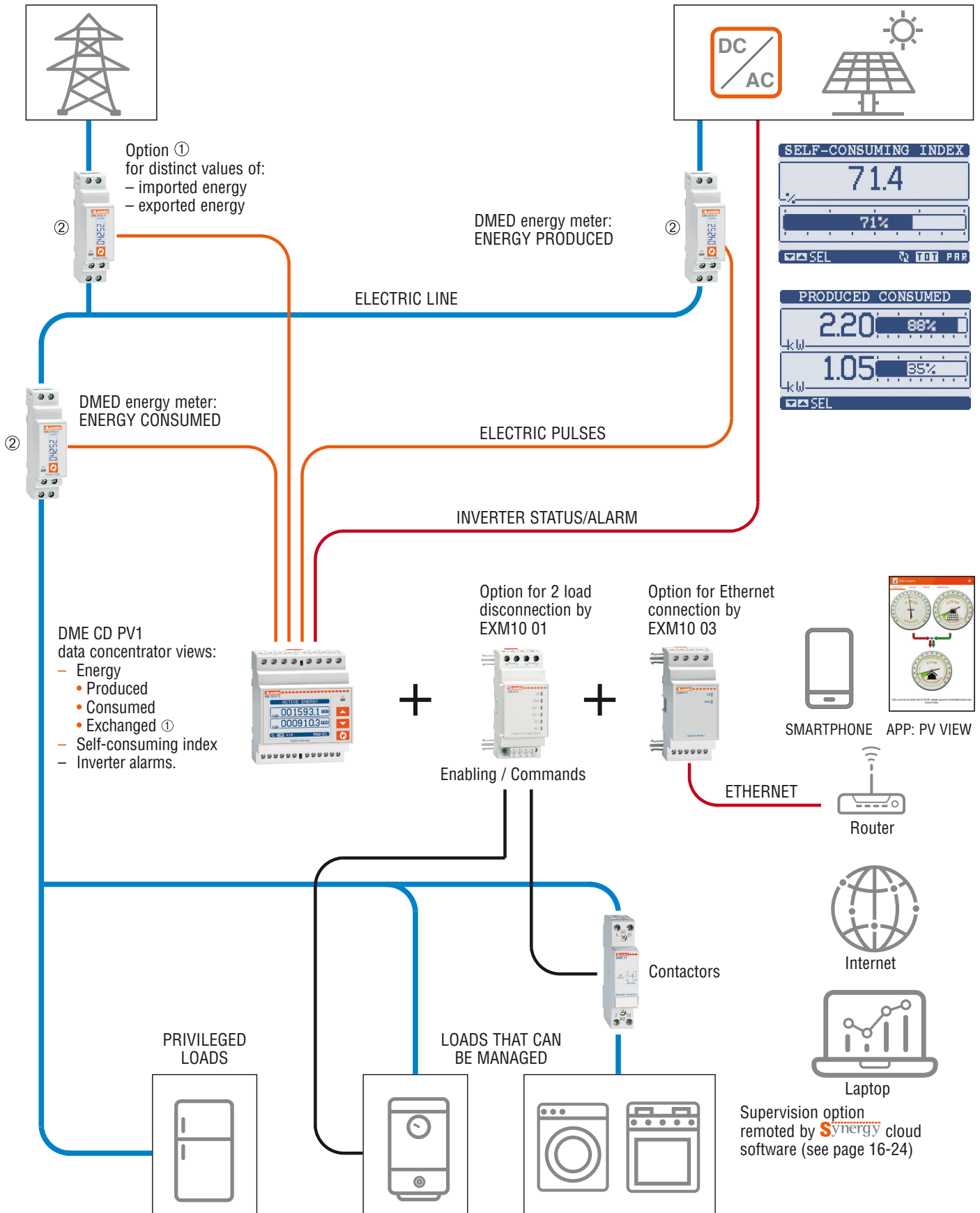

① If the distinct values of import and export energy need to be known, a third energy meter should be installed on the in-coming line; the exchanged energy is the difference between import and export energy with the power supplier.
② The energy meters can be single or three phase based on the type of installation.

Energy Meters

Mechanical meter **DME M100...**
Digital meter **DME D100... - DME D110...**

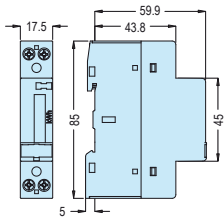

Digital meter **DME D115 T1 - DME D120 T1...**
DME D121 - DME D130

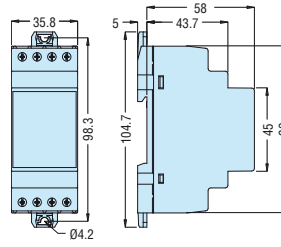

Digital meter **DME D300 T2... - DME D300 F - DME D310 F... - DME D310 T2... - DME D330 - DME D301 - DME D305 T2**
Data concentrator **DME CD - DME CD PV1...**

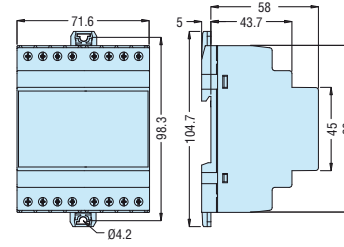

Multimeters

DMG 100 - DMG 101 - DMG 110 - DMG 200 - DMG 210 - DMG 300

Expansion modules **EXM...**

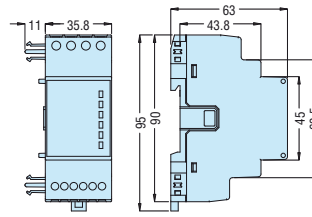
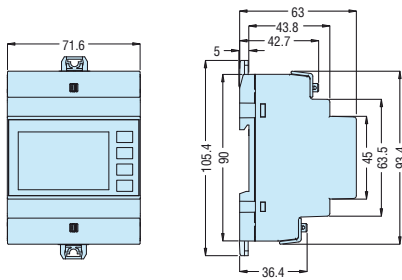

DMG 600 - DMG 610

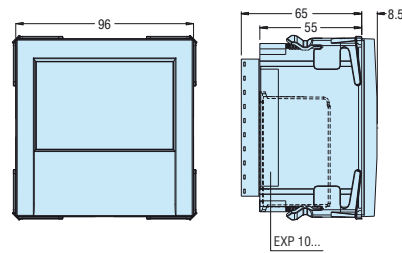

DMG 700 - DMG 800... - DMG 900... with expansion modules EXP...

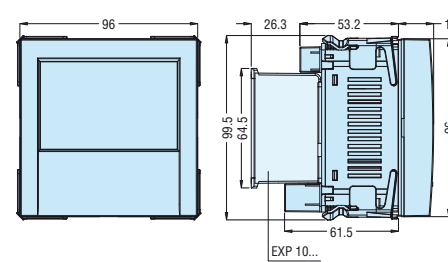

Cutout

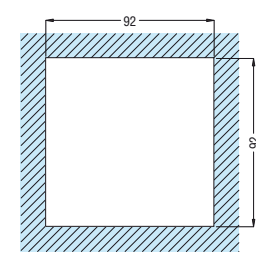

Transducer **DMG 900T** with expansion modules **EXP...**

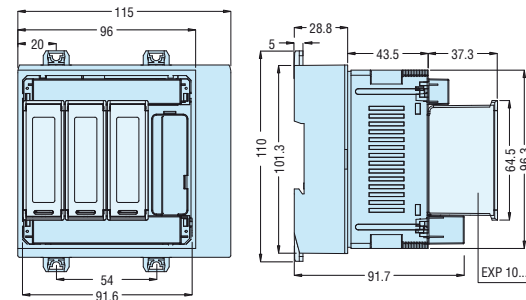

DMG 900RD remote display

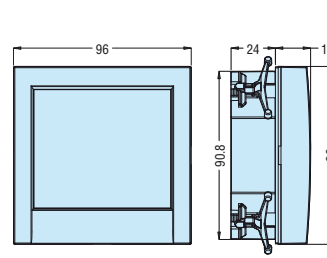

Cutout

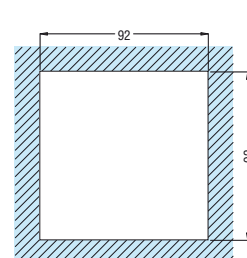

Flush-Mount Metering Instruments

Instruments **DMK 0... - DMK 1...**

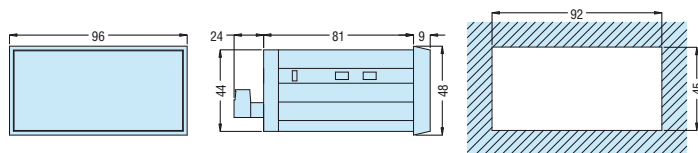

Cutout

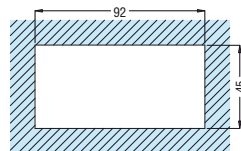

Flush-Mount Multimeters

DMK 2...

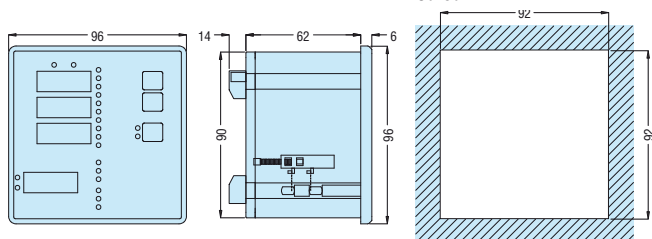

Cutout

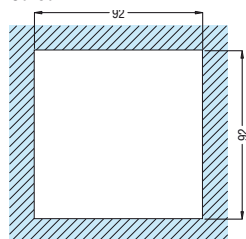

METERING INSTRUMENTS AND CURRENT TRANSFORMERS

Dimensions [mm]



Digital Metering Instruments

DMK 7... - DMK 8...

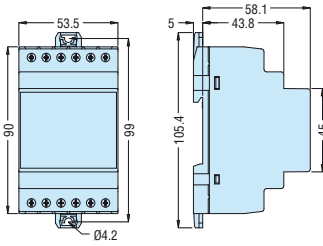

Current Transformers

Solid core **DM0T...**

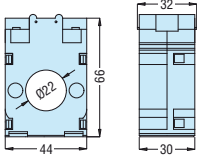

DM2T...

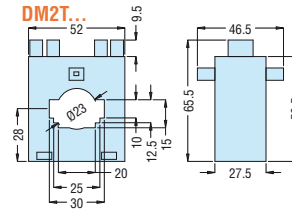

DM3T...

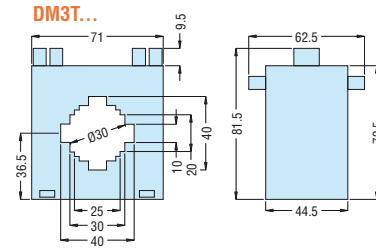

DM35T...

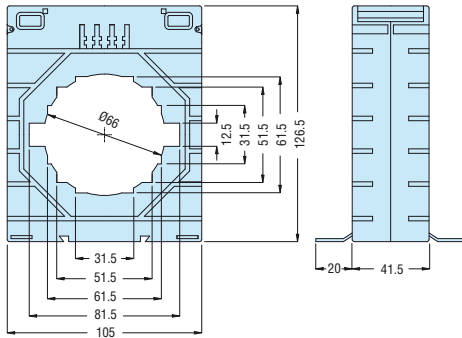

DM4T...

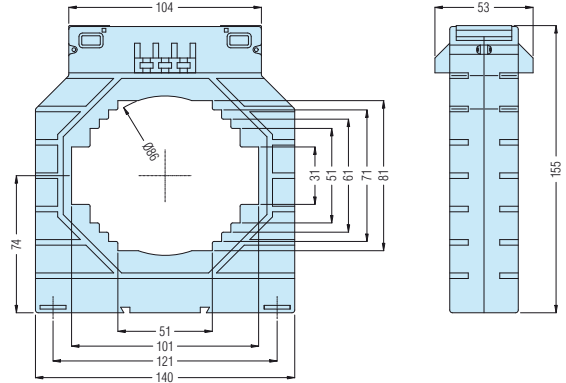

DM1TP0060... - DM1TP0300

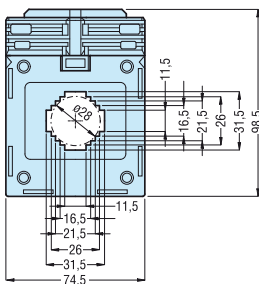

DM1TP0400... - DM1TP0500

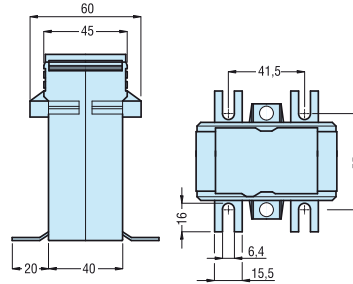
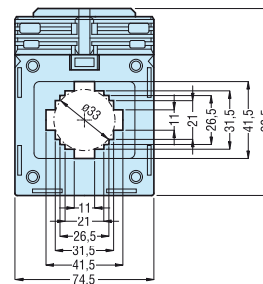

DM3TP...

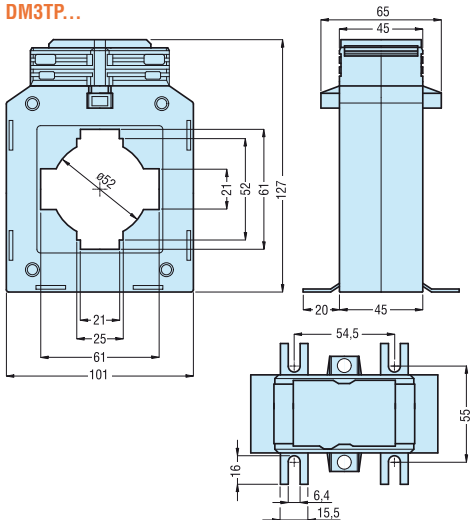

DM5TP...

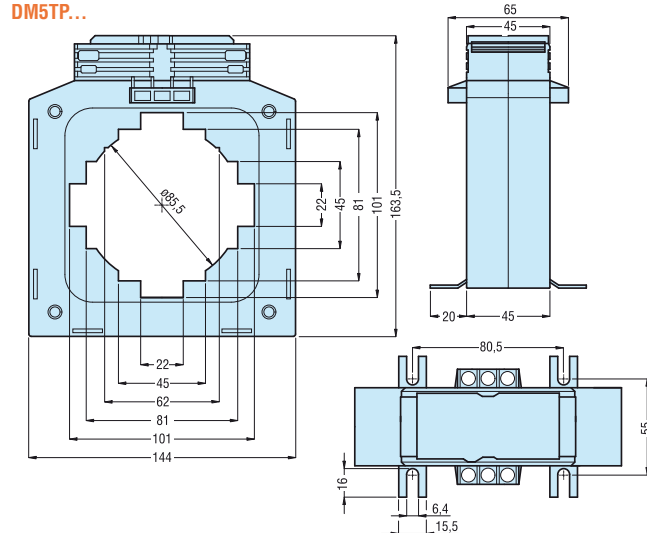

Current Transformers

Compact prewired split-core

DM1TMA...

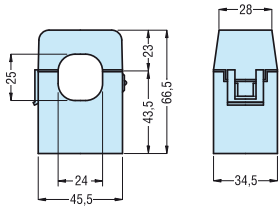

DM2TMA...

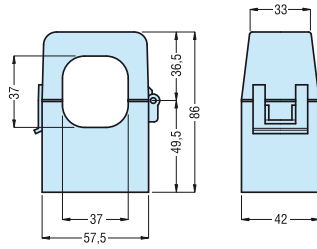

Split-core **DM1TA...**

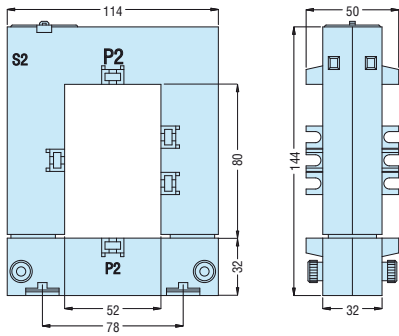

DM2TA...

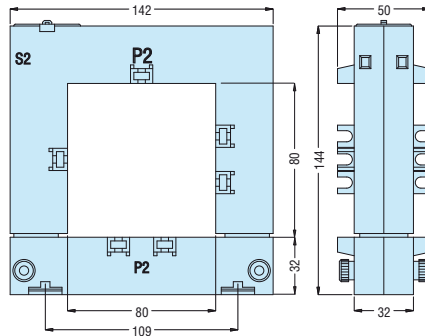

DM3TA...

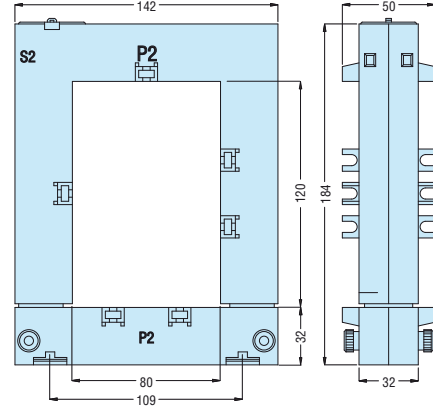

DM4TA...

